

Kirby Morgan Band Mask KMB-18 A/B and KMB-28B



Operations and Maintenance Manual

KMB 18 & 28 MANUAL

On the cover, the KMB 18B (shown with the Tri-Valve™ Exhaust, Band Keepers™ and the Optional Head Protector) and KMB 28B

**Kirby Morgan Band Mask
KMB 18A/B and KMB 28
Operations and Maintenance Manual
KMDSI Part # 100-002**



Kirby Morgan Dive Systems, Inc.
425 Garden Street
Santa Barbara, CA 93101, USA
Telephone (805) 965-8538
FAX (805) 966-5761
E-Mail: Info@KMDSI.com
Web Site: www.KMDSI.com

! DANGER: Diving with compressed breathing gas is a hazardous activity. Even if you do everything right there is always the potential for serious injury or death. No one piece of diving equipment can prevent the possibility that you may be injured or killed any time you enter the water. We do not herein make any effort to teach the principles of diving. It is our assumption the reader is a qualified diver.

Manual prepared by Marine Marketing and Consulting & Kirby Morgan Dive Systems, Inc.

SuperLite-17, SuperLite-27, SuperLite-17C, SuperLite-17K, Band Mask, Kirby Morgan, DCS-2A and KMB are all registered trademarks of Kirby Morgan Dive Systems, Inc. Use of these terms to describe products that are not manufactured by KMDSI is not permitted.

© Copyright 1970-2004 Kirby Morgan Dive Systems, Inc. All rights reserved. This manual is made available for the express use of owner of this Kirby Morgan product. No part of this manual may be reproduced, stored in any retrieval system, or transmitted, or used in any form or by any means, whether graphic, electronic, mechanical, photocopy, or otherwise by technology known or unknown, without the prior written permission of Kirby Morgan Dive Systems, Inc.

KMB 18 & 28 MANUAL

This page not used at this time.

Contents

KMB 18 & 28 MANUAL

DEFINITION OF SIGNAL WORDS	1
IMPORTANT SAFETY INFORMATION	2
WARRANTY INFORMATION	4
Chapter 1 GENERAL INFORMATION	7
1.1 INTRODUCTION	7
1.2 KMB 18A, KMB 18 B and KMB 28 BAND MASK CONFIGURATIONS	10
1.3 DESIGN PURPOSE	10
1.4 CONSTRUCTION SPECIFICATIONS	11
1.5 GENERAL DESCRIPTION	11
1.5.1 Gas Flow Systems	11
1.5.2 Auxiliary Gas Supply System	13
1.5.3 Reducing Carbon Dioxide	14
1.5.4 Main Exhaust System	14
1.5.5 Communications	15
1.5.6 Hood and Face Seal	15
1.5.7 Hood and Face Seal Retainer Bands & Band Keepers™	15
1.5.8 Head Harness or Spider	15
1.6 IMPORTANCE OF PROPER MAINTENANCE	15
1.6.1 Special Tools	16
Chapter 2 OPERATING INSTRUCTIONS	17
2.1 INTRODUCTION	17
2.1.1 First Use of Kirby Morgan 18A/B & 28	17
2.2 PRE DRESS-IN PROCEDURE	18
2.2.1 Pre-dive Inspection	18
2.2.2 Clean Face Port	19
2.2.3 Check Moving Parts	19
2.2.4 One Way Valve Check	19
2.2.5 Connecting the Band Mask to the Diver's Umbilical	20
2.2.6 Gas Flow Systems Check	21
2.2.7 Sealing Integrity Check	22
2.2.8 Check Communications	22
2.3 DIVING PROCEDURES	22
2.3.1 Fogging Prevention	22
2.3.2 Bleeding the Umbilical	23
2.3.3 Auxiliary Gas System	23
2.3.4 Securing the Band Mask on the Diver	26
2.3.5 Attaching the Umbilical to the Harness	27

KMB 18 & 28 MANUAL

2.3.6	Diver Check Gas Flow Systems	28
2.3.7	Communications Check	28
2.3.8	Diver Ready	28
2.3.9	Water Entry and Descent	28
2.4	EMERGENCY PROCEDURES	29
2.4.1	Flooding	29
2.4.2	Inhalation Resistance	29
2.4.3	Gas Flow Stops	29
2.4.4	Demand Regulator Free Flow	30
2.5	POST DIVE PROCEDURES	30
2.5.1	Removing the Equipment	30
	Chapter 3 TROUBLESHOOTING	31
3.1	GENERAL	31
3.2	COMMUNICATIONS MALFUNCTIONS	31
3.3	ONE-WAY VALVE MALFUNCTION	32
3.4	SIDEBLOCK MALFUNCTION	32
3.5	DEMAND REGULATOR MALFUNCTION	33
3.6	WATER LEAKAGE INTO BAND MASK	34
3.7	AUXILIARY VALVE MALFUNCTION	34
	Chapter 4 INSPECTION/MAINTENANCE TIMETABLE	35
4.1	DAILY MAINTENANCE	35
4.2	MONTHLY MAINTENANCE	35
4.3	EVERY SIX MONTHS OR 200 OPERATING HOURS	35
4.4	YEARLY OR EVERY 400 OPERATING HOURS	36
	Chapter 5 PREVENTATIVE MAINTENANCE	37
5.1	INTRODUCTION	37
5.2	REQUIRED TOOLS, CLEANING AGENTS, AND LUBRICATING AGENTS	37
5.2.1	Component and Parts Cleaning	38
5.2.2	Component and Parts Lubrication	38
5.2.3	Teflon Tape	38
5.2.4	RTV Sealant	38
5.3	GENERAL	39

5.4	DAILY MAINTENANCE	39
5.5	MONTHLY MAINTENANCE (OR BETWEEN JOBS)	41
5.5.1	Communications Inspection	41
5.5.2	Lubricate Nose Block O-Rings.....	41
5.5.3	ONE-WAY VALVE	42
5.5.3.1	Disassembly of the One-Way Valve	42
5.5.3.2	Reassembly of the One-Way Valve	43
5.5.4	DEMAND REGULATOR	44
5.5.4.1	Demand Regulator Test for Correct Adjustment, Fully Assembled	44
5.5.4.2	Inspection of Regulator Body Interior	45
5.5.5.1	Adjustment System Lubrication	45
5.5.5.2	Reassembly of Adjustment System	47
5.6	DEMAND REGULATOR INTERNAL ADJUSTMENT	48
5.7	HOOD AND FACE SEAL	50
5.7.1	Hood and Face Seal Removal.....	50
5.7.2	Hood and Face Seal Replacement	51
Chapter 6	CORRECTIVE MAINTENANCE	53
6.1	GENERAL	53
6.2	PORT RETAINER	53
6.3	FACE PORT	53
6.3.1	General.....	53
6.3.2	Face Port and Nose Block Device Removal.....	54
6.3.3	Face Port and Nose Block Replacement.....	55
6.4	COMMUNICATIONS SYSTEM.....	57
6.4.1	General.....	57
6.4.2	Earphone Inspection	57
6.4.3	Microphone Removal and Replacement.....	58
6.4.4	Earphone Removal and Replacement	59
6.4.5	Waterproof Connector	59
6.4.5.1	Waterproof Connector Removal	59
6.4.5.2	Connector Replacement.....	60
6.4.6	Communications Posts	60
6.4.6.1	Communications Post Removal	60

KMB 18 & 28 MANUAL

6.4.6.2	Communications Post Replacement	61
6.5	SIDEBLOCK ASSEMBLY	61
6.5.1	General.....	61
6.5.2	Sideblock Assembly Removal	62
6.5.2.1	KMB 18A	62
6.5.2.2	KMB 18B & 28	62
6.5.2.3	Separating the Sideblock Assembly from the Band Mask Frame	63
6.5.3	Sideblock Assembly Replacement.....	64
6.6	DEFOGGER VALVE	66
6.6.1	Disassembly of the Defogger Valve	66
6.6.2	Cleaning and Lubricating	67
6.6.3	Reassembly of the Defogger Valve	67
6.7	AUXILIARY GAS SUPPLY VALVE ASSEMBLY	68
6.7.1	Disassembly of the Auxiliary Valve Assembly.....	68
6.7.2	Cleaning and Lubricating	68
6.7.3	Reassembly of Auxiliary Valve	69
6.8	MODEL "A" REGULATOR HOSE ASSEMBLY	70
6.8.1	Hose Removal	70
6.8.2	Inspection, Cleaning, and Lubricating.....	70
6.8.3	Hose Replacement	71
6.9	"B" BENT TUBE ASSEMBLY	72
6.9.1	General.....	72
6.9.2	Removal of the Bent Tube Assembly	72
6.9.3	Inspection of Bent Tube Assembly	72
6.9.4	Replacement of the Bent Tube Assembly.....	73
6.10	NOSE BLOCK ASSEMBLY.....	74
6.10.1	Nose Block Assembly Removal	74
6.10.2	Nose Block Device Replacement	74
6.11	BAND MASK FRAME KMB 18A/B	74
6.12	Tri-Valve™ Exhaust	75

6.12.1 Tri-Valve™ Exhaust Assembly Removal 75

6.12.2 Tri-Valve™ Exhaust Valve and Regulator Exhaust Valve Replacement 75

6.12.2.1 Tri-Valve™ Exhaust Valve Replacement 75

6.12.2.2 Regulator Exhaust Replacement 76

6.12.3 Tri-Valve™ Exhaust Assembly Installation 76

6.13 MAIN EXHAUST ASSEMBLY 77

6.13.1 Exhaust Valve Removal 77

6.13.2 Main Exhaust Body Replacement 78

6.14 DEMAND REGULATOR ASSEMBLY 78

6.14.1 General 78

6.14.2 Demand Regulator Assembly Removal 78

6.14.3 Disassembly of the Demand Regulator 79

6.14.4 Inspection of Demand Regulator Parts 80

6.14.5 Reassembly of the Demand Regulator 81

6.14.6 Unexplained Demand Regulator Steady Flow When Underwater 83

6.15 ORAL NASAL MASK 84

6.15.1 Oral Nasal Mask Removal 84

6.15.2 Inspection of Oral Nasal Mask 84

6.15.3 Oral Nasal Mask Replacement 84

6.15.4 Oral Nasal Valve Replacement 84

Chapter 7 ACCESSORIES 85

7.1 INTRODUCTION 85

7.2 HOT WATER SHROUD INSTALLATION PROCEDURES 85

7.3 LOW PRESSURE INFLATOR HOSE INSTALLATION ON THE “B” SIDEBLOCK 87

7.4 WELD LENS ASSEMBLY INSTALLATION INSTRUCTIONS 87

7.5 USE OF QUICK-DISCONNECT 88

7.6 MASK CARRYING BAG 88

Appendix I Torque Specifications 89

Appendix 2 Maintenance Log 90

Table of Equivalents 91

This page not used at this time

Definitions of Signal Words Used in this Manual

For your protection, pay particular attention to items identified by signal words in this manual. These terms are identified as, CAUTION, WARNING AND DANGER. It is especially important for you to read and understand these signal words.

 **CAUTION:** This word indicates a potentially hazardous situation which, if not avoided, may result in minor or moderate injury. It may also be used to alert against unsafe practices.

 **WARNING:** This word indicates a potentially hazardous situation which, if not avoided, could result in death or serious injury.

 **DANGER:** This word indicates an imminently hazardous situation, which if not avoided, will result in death or serious injury.

If English is not your native language and you have any difficulty understanding the language of any warnings as they appear in the manual, please have them translated.

 **WARNING:** Este é um aviso importante. Queira mandá-lo traduzir.

 **WARNING:** Este es un aviso importante. Sirvase mandario traducir.

 **WARNING:** Quest è un avviso importante. Tradurlo.

 **WARNING:** Ceci est important. Veuillez traduire.

 **WARNING:** Diese Mitteilung ist wichtig. Bitte übersetzen lassen.

If you have any questions regarding the information in this manual, or the operation of your mask, call Kirby Morgan Dive Systems, Inc. at (805) 965-8538 or E-Mail: Info@KMDSI.com

IMPORTANT SAFETY INFORMATION

This Kirby Morgan Band Mask (KMB 18 A/B & 28) diving mask is intended for use only by trained divers who have successfully completed a recognized training course in surface supplied diving.

 **WARNING:** Follow all the instructions in this manual carefully and heed all safety precautions. Improper use of this diving mask could result in serious injury or death.

 **DANGER:** Kirby Morgan Dive Systems, Inc. (KMDSI) warns all divers who use the Kirby Morgan Band Mask (KMB 18A/B & 28) to be sure to use only KMDSI original spare parts from a KMDSI authorized dealer. Although other parts, O-rings and fittings may appear to fit on the Kirby Morgan Band Mask (KMB 18A/B & 28), they may not be manufactured to the same standards maintained by KMDSI. The use of any parts other than KMDSI original parts may lead to equipment failure and accidents.

 **DANGER:** Diving in an environment that is chemically, biologically, or radiologically contaminated is extremely hazardous. Although the Kirby Morgan Band Mask (KMB 18A/B & 28) may be adapted for use in some contaminated environments, special training, equipment, and procedures are necessary. Do not dive in a contaminated environment unless you have been thoroughly trained and equipped for this type of diving.

Read this manual before using or maintaining the mask, even if you have experience with other diving masks. If you have purchased the mask new from a dealer, be sure to send in the warranty registration card so we may keep you informed regarding any safety notices that affect this product. If you resell or loan this mask to another diver, be sure this manual accompanies the mask and that the person reads and understands the manual.

 **DANGER:** Diving is a life threatening occupation. Even if you do everything right there is still the potential for serious injury or death. Diving a Kirby Morgan band mask or helmet cannot prevent accidents, injuries, or death.

 **WARNING:** This mask was completely checked and should be ready to dive as it was shipped from the factory. However, it is always the diver's responsibility to check all the components of the mask prior to diving.

This manual is supplied to the original purchaser of this mask. If you have any questions about the use, maintenance, or operation of this mask, or you need another copy of this manual, Part Number 100-002, contact your nearest KMDSI dealer or Kirby Morgan Dive Systems, Inc. (KMDSI). Telephone:(805) 965-8538, Fax: (805) 966-5761, E-Mail: Info@KMDSI.com

 **DANGER: Kirby Morgan masks and helmets are not cleaned or lubricated for oxygen service. Using this mask with oxygen percentages above 50% by volume may lead to fire or explosions that can result in serious injury or death.**

All Kirby Morgan helmets and masks must not be used with oxygen breathing mixtures in excess of 50% by volume without first insuring all gas transporting components have been cleaned and lubricated for oxygen service. Only oxygen compatible lubricants such as Krytox® and Christo lube® should be used. Lubricants must be used sparingly.

The information contained in this manual is intended to aid the user in optimizing the performance of this helmet. Some of the information will depend on the diving situation and the use of associated equipment. Many countries have specific laws and rules regarding commercial diving. The operating and performance specifications listed in this manual on page 8 is separated into two charts. These charts demonstrate different operation requirements, which are required or imposed by countries or regulating bodies. It is important for the user to understand the rules, regulations, and philosophy imposed by the governing regulating bodies whenever using commercial diving equipment. These charts show the basic operating pressures, depths, and umbilical configurations as required by some regulating bodies. Whenever Kirby Morgan helmets or masks are used in European Countries, which have adopted the C.E. certification programs they must only be used with C.E. certified components. Diving operations should only be conducted within the limits of the operational specifications, and in accordance with the rules and regulations established by the governing authority in the specific country or geographical location where the diving operations are being conducted. Please call Kirby Morgan Dive Systems, Inc. (KMDSI) regarding any operational or performance questions.

Warranty Information

Kirby Morgan Dive Systems, Inc. (KMDSI) warrants every new mask, helmet, or Dive Control System (DCS) to be free from defects in workmanship for a period of ninety (90) days from date of purchase. This warranty does not cover rubber parts or communications components.

Should any part become defective due to materials or workmanship during the warranty period, contact your nearest authorized KMDSI dealer. If there is no dealer in your area, contact KMDSI directly at (805) 965-8538, E-Mail: Info@KMDSI.com or Fax (805) 966-5761. You must have a return authorization number (RMA#) from KMDSI prior to the return of any item. Upon approval from KMDSI, return the defective part, freight prepaid, to KMDSI, 425 Garden Street, Santa Barbara, CA, 93101. The part will be repaired or replaced at no charge as deemed necessary by KMDSI.

This warranty becomes null and void if:

- 1. The product is not registered with KMDSI within ten (10) days of purchase.**
- 2. The product has not been properly serviced and maintained according to the appropriate KMDSI manual.**
- 3. Unauthorized modifications have been made to the product.**
- 4. The product has been abused or subjected to conditions which are unusual or exceed the product's intended service.**

This page not used at this time

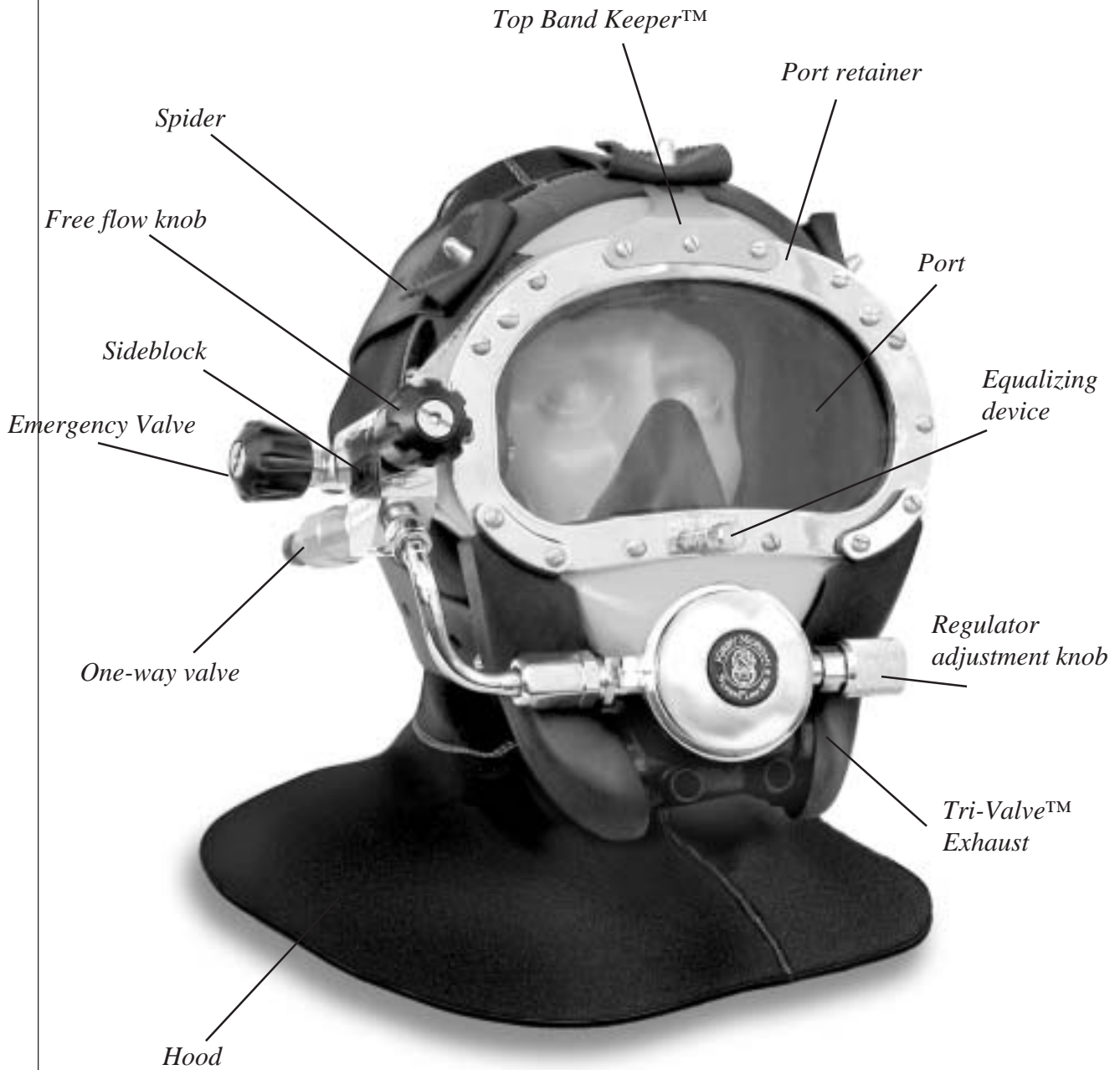

The KMB 18B Band Mask

STOP!
BEFORE GOING FURTHER-

Locate the exploded view at the back of this manual. Fold it out and follow the numbers as you read. All the numbers in parentheses in the text refer to the numbers on the exploded drawing. These numbers are called "location" numbers on the parts list. They are used to find the referred to parts on the exploded drawing only. **They are not the part number.** Always check the part number when ordering to make sure it is correct. Always specify the mask model number as well. There is only one exploded view drawing which includes both the Kirby Morgan Band Mask (KMB 18A) and Kirby Morgan Band Mask (KMB 18B), as well as the Kirby Morgan KMB 28 Band Mask.

CHAPTER 1

GENERAL INFORMATION

1.1 INTRODUCTION

Kirby Morgan Dive Systems, Inc. (KMDSI) started as the Kirby Morgan Corporation in 1965. Kirby Morgan is a registered trademark for our products.

William Bev Morgan started designing and making diving equipment shortly after becoming a breath-hold diver while working as a beach lifeguard in the late 1940's. There was very little equipment available in those early days so it was necessary to make much of his own gear.

During the early 1950's he originated the Los Angeles (California) Underwater Instructor Program for teaching SCUBA divers/instructors, then started Dive 'N Surf, one of the first diving equipment suppliers that integrated Scuba diving instruction into the same operation as sales and service of equipment. He, along with his partners, Bill and Bob Meistrell, designed and manufactured diving equipment that remains a standard in the diving industry today.

In 1957 Morgan sold Dive 'N Surf to his partners. In 1960 he started commercial diving along with designing and making diving equipment for the commercial market.

The Kirby Morgan Corporation was formed to manufacture commercial diving helmets. The copper and brass "heavy gear" or "Standard Dress" helmets were the first manufactured by the com-

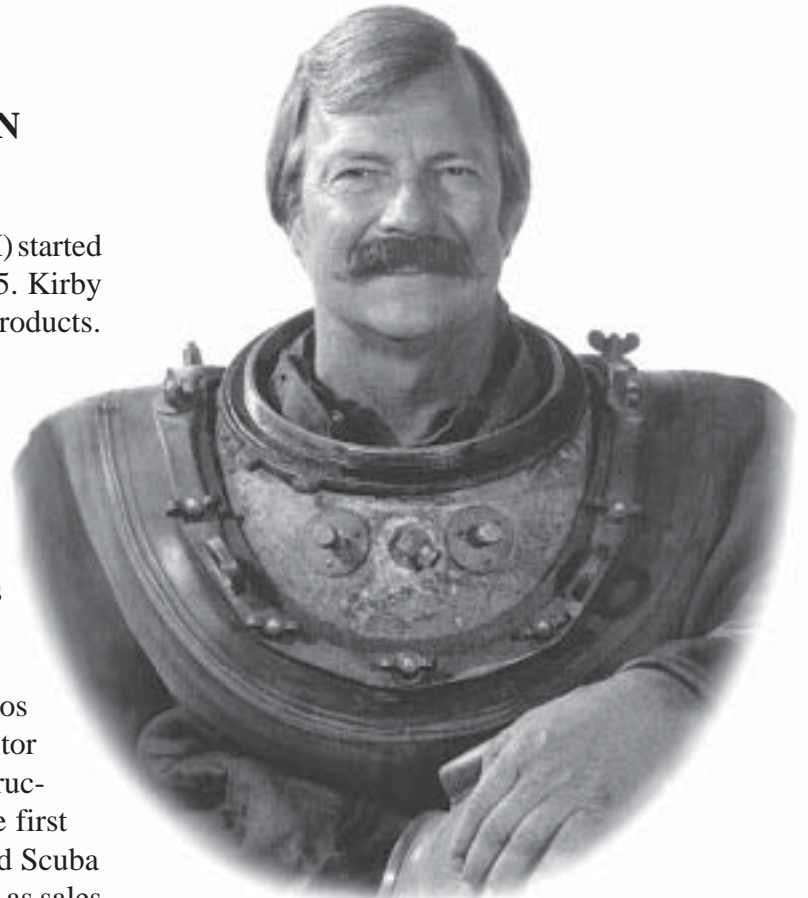

*Bev Morgan, Chairman of the board,
Kirby Morgan Dive Systems, Inc.*

pany. Over the years Kirby Morgan designed, manufactured, and sold many different helmets and masks for commercial divers.

Staying active in commercial diving has contributed to the successful design innovations of KMDSI products. This may be the primary reason for the acceptance of our designs by professional divers. Over the years, Morgan has designed more than forty diving helmets and forty five diving masks.

KMB 18 & 28 MANUAL

All members of the KMDSI staff participate as part of the Kirby Morgan design team. It would not be possible for us to supply the commercial, military, scientific, and public service diving industries with our equipment without the team of people that make up Kirby Morgan Dive Systems, Inc. (KMDSI)

We feel it is important for the reader to understand that we at KMDSI consider ourselves as only part of the process along the path in diving equipment design. We welcome all input from our customers. The thinking of many good divers, diving equipment engineers, diving medical specialists, diving organization administrators and their supporting personnel has contributed to the current state of the art of diving.

Each piece of gear we manufacture has in it some of the thinking of those who have gone before us. To all the people who give something of themselves to the men and women who work underwater, we express a thank you.

Our extensive dealer network makes it easy to obtain genuine Kirby Morgan replacement parts as well as technical assistance world wide. We have a strong commitment to providing the best diving equipment and service possible.

Kirby Morgan has always concentrated on designing and manufacturing diving equipment that allows most repairs and routine maintenance to be performed by the user. The KMB 18/28 full face mask is no exception. Most routine preventative and corrective maintenance can be accomplished by the user utilizing this manual, the KMDSI Tool Kit and common hand tools.

The side block and regulator are of a U.S. Navy approved design, engineered to provide an optimum flow of breathing gas even under heavy work conditions.

The mask has been tested and conforms to the performance requirements as set forth in Annex

II of Directive 89/686/EEC and as far as applicable, the EN250 (edition Jan 2000) and the E DIN 58 642 (edition Feb 1998). When the mask is used for air diving in countries that conform to C.E. regulations it may be used to a maximum depth of 164fsw (50 msw). I.A.W. EN250.

Only equipment certified and tested according to EN 250/E DIN 58 642 may be used with the KMB 18/28 when conducting diving operations in European EC compliant countries.

Performance of the mask is dependant on many factors including type of breathing gas used, work rate, delivery pressure, umbilical internal diameter, length and number of connections, diving depth and capability of the gas delivery system to provide breathing media at the required CFM or LPM to maintain the optimum static over bottom pressure. Performance of this helmet is measured in volume averaged pressure, resistive effort, formally called work of breathing. Volume averaged pressure is the measurement of average pressures contributed by resistive components within the UBA. This value is normally expressed in Joules/liter. The performance of this mask can be expected to be less than 3.0 J/L when used within the following guidelines.

Operational Specifications and Limitations:

- Maximum depth on air - 220 fsw (67 msw) with the standard exhaust whisker assembly.

- Maximum depth on air - 100 fsw (30 msw) when equipped with the double exhaust whisker assembly*.

Work rate - moderately heavy - 62.5 lpm rmv.

-Umbilical minimum I.D. 3/8" (9.5 mm) of one continuous length (no splice), total length not to exceed 600 feet (182m).

-Required over-bottom supply pressure,
0-100 fsw (0-30 msw), 115-135 psig (8-9.3 bar).
100-150 fsw (30-50 msw), 135-225 psig (9.3-15.5 bar).
100-220 fsw (30-67 msw), 175-225 psig (12.0-15.5 bar).

-Gas supply system capable of supplying 4.5 acfm (127.4 BL/min) to the side block assembly at depth.

-Temperature limitations: Use at water temperatures below 36° F (2°C) requires use of hot water shroud and hot water.

The umbilical assembly should be composed of good quality diving hose that meets industry standards. Generally, gas hose will be married to the communications wire, pneumofathometer hose, and strength member in a manner that will allow the strength member to receive all the strain. There are also good quality umbilicals available that are assembled at the factory using a twisted method which does not require marrying. Regardless of the system used, the umbilical is the divers life line and should always be of excellent quality and maintained carefully.

*** This assembly has not been tested for CE compliance.** Hooded face masks should **NOT** be used for diving in contaminated water situations. The double exhaust is provided for the masks for use during jetting operations. It has been found that the use of a double exhaust assembly can help in the prevention of inversion of the exhaust valve during heavy jetting operations.

The diving control station can be at the surface, in a diving bell, or out of a submerged habitat. The diving control station is the center of the air/gas supply, communications with the diver, and diving procedures.

! DANGER: Decompression diving always involves the risk of decompression sickness. Omitted decompression due to loss of gas supply or other accidents can cause serious injury or death. Use of a KMB 18/28 mask cannot prevent this type of injury.

! WARNING: High pressure regulators and associated piping systems for surface supplied diving with Kirby Morgan helmets and masks must be capable of delivering a minimum of 4.5 acfm to the diver at depth. Only systems that can deliver this required gas flow should be used. The use of standard SCUBA style regulators stationed top side is unacceptable as there is no provision for adjusting the intermediate pressure supplied to the diver. This can create a dangerous situation where the diver may not receive an adequate supply of air. Only regulators which allow a variable setting for intermediate pressure should be used for umbilical diving.

Many of the parts on the Kirby Morgan Band Mask (KMB 18A/B) are interchangeable with our SuperLite Helmets, and the Kirby-Morgan Band Mask 28. This helps keep inventory costs low for diving companies and independent divers.

The KMB 28 has a durable injection molded plastic frame (17) rather than a fiberglass frame as found in the KMB 18A/B.

The KMB 28 uses the SuperFlow regulator, the KMB 18 uses the large tube SuperFlow 350 regulator.

KMB 18 & 28 MANUAL

Additional differences between the Kirby Morgan Band Mask KMB 18A/B and the Kirby Morgan Band Mask KMB 28 are as follows:

- 1) The face port (27) in the KMB 28 is a slightly different size than the KMB 18A/B.
- 2) The main exhaust body (67) is molded into the mask frame in the KMB 28.
- 3) The exhaust covers on the two masks are slightly different.
- 4) There is a vacuum formed comfort insert (14) in the KMB 18A/B.
- 5) The air train in the KMB 28 requires a special standoff (24) for proper mounting of the side block.

It is our hope that the Kirby Morgan Band Mask (KMB 18A/B or KMB 28), will provide comfort and safety to your diving. This manual is our effort to explain the operation, maintenance and use of the Kirby Morgan Band Mask (KMB 18A/B & 28).

 **WARNING: We do not herein make any effort to teach the principles of diving. It is our assumption the reader is a qualified diver.**

If there is any information in this manual that is not clear, contact Kirby Morgan Dive Systems, Inc. at (805) 965-8538 for clarification.

1.2 KIRBY MORGAN BAND MASK A (KMB 18A), KIRBY MORGAN BAND MASK B (KMB 18B), AND KIRBY MORGAN BAND MASK 28 (KMB 28) CONFIGURATIONS

The Kirby Morgan Band Mask 18 (KMB 18) is manufactured in two configurations. With the exception of the side block assembly (120a/b), the hose assembly (117a) with its inlet nipple (61a), and the bent tube assembly (117b) with its

inlet nipple (61b) and jam nut (61c), the two models are identical. The configuration of the KMB 28 is almost identical to the KMB 18B.

The Kirby Morgan Band Mask A (KMB 18A) side block assembly (120a) receives the main and auxiliary gas supplies from hoses that run down in front of the diver. The Kirby Morgan Band Mask 18B (KMB 18B) side block assembly (120b) receives the hoses from over the diver's shoulder. All "location" numbers that are for the "A" model will have a small "a" and all "location" numbers for the "B" only will have a small "b".

Some divers prefer the hoses to go over their shoulder to clear their front when working. Others prefer the hoses to go down their front to prevent fouling. It depends on the type of work and what the diver finds comfortable.

1.3 DESIGN PURPOSE

The Kirby Morgan Band Masks 18A/B & 28 are designed for use with an umbilical.

 **WARNING: Only under very controlled conditions, i.e., non-moving water (such as swimming pools or calm lakes), can this mask be used with a self contained gas supply. There is no provision for surface swimming once the SCUBA air supply is depleted**

The umbilical is usually composed of at least a gas or air supply hose and communication wire, assembled with waterproof tape to form a single unit. Some umbilicals also have included a hose for hot water, a pneumofathometer hose, and a strength member, such as a cable or strong line. It is imperative that air/gas umbilicals be married to a strength member in a manner that allows the strength member to receive the strain. This will help reduce the possibility of umbilical and umbilical fitting fatigue and possible failure. The umbilical is the diver's lifeline to the diving control station.

The diving control station can be at the surface, in a diving bell, or out of a submerged habitat. The diving control station is the center of the air/gas supply, communications with the diver, and diving procedures.

 **DANGER:** Decompression diving always involves the risk of decompression sickness. Omitted decompression due to loss of gas supply or other accidents can cause serious injury or death. Use of a KMB 18/28 mask cannot prevent this type of injury.

 **WARNING:** High pressure regulators for surface supplied diving with the Kirby Morgan Band Mask 18A/B and KMB 28 mask must be capable of supplying an over bottom pressure of between 115 and 225 PSI. The use of standard SCUBA style regulators stationed top side is unacceptable as there is no provision for adjusting the intermediate pressure supplied to the diver. This can create a dangerous situation where the diver may not receive an adequate supply of air. Only regulators which allow a variable setting for intermediate pressure should be used for umbilical diving.

The surface supplied diver's mask must provide life support breathing systems, communications components, viewing lens, and many other less important, but vital systems. The Kirby Morgan Band Masks 18A/B and 28 provides these systems in a convenient and comfortable way.

1.4 CONSTRUCTION SPECIFICATIONS

KIRBY MORGAN BAND MASK

KMB 18A/B & 28

Weight: 11 pounds

CONSTRUCTION:

Mask Frame KMB 18A/B, Fiberglass

Mask Frame KMB 28, Xenoy/Polycarbonate mix

HARDWARE:

Stainless Steel, Chromed Brass, Polished Brass

CONTROL KNOBS: ABS Plastic

LENS: Polycarbonate plastic

O-RINGS: Buna-N

HOOD: Foam, Open Cell Neoprene

RECOMMENDED LUBRICANTS:

Dow Corning #55 O-ring silicone lubricant.

Krytox, and Crysto Lube are also acceptable.

OPERATING PRESSURE: 115-225 PSI over ambient.

Optimum 150 PSI over ambient

FLOW REQUIREMENTS: 3.2 CFM

COMMUNICATIONS:

Earphones - Mylar Cone 8 OHM

Oral Nasal Microphone - 8 OHM

1.5 GENERAL DESCRIPTION

1.5.1 Gas Flow Systems

The main gas supply flow from the umbilical enters the system at the adapter (105) and flows through the automatic one-way valve (104) to the interior of the side block assembly (120a/b). The one-way valve (104) or "non-return" is a very important component. It must prevent the flow of gas out of the mask to the umbilical in the event of a sudden lowering of pressure in the supply hose. This can happen due to an accidental break in the hose or a fitting near the surface. Not only would the auxiliary gas be lost if the one way valve failed (concurrent with a hose or fitting break on deck), but the diver would be "squeezed", a very serious accident. Although we have se-

KMB 18 & 28 MANUAL

lected the valve for its reliability and quality, inspection and maintenance of this valve must be done regularly. It is very easy to disassemble and inspect. (A rebuild kit for this valve is available, KMDSI Part #525-330).

⚠ WARNING: The one way valve must be tested daily, prior to the commencement of diving operations. Failure of the one way valve could cause serious injury or death. Follow the procedures for testing the valve in chapter 2 (sec. 2.2.4) of this manual.

The auxiliary gas comes from a tank of compressed gas worn by the diver. It enters the system through the auxiliary valve (103) when the diver turns the control knob (100) on. The flow then enters the side block, (94a/b).

⚠ WARNING: Never connect the main gas supply hose from the diving station to the auxiliary valve (103). There is no one way valve in the auxiliary valve. If this mistake is made, any break in the supply hose could possibly result in a “squeeze”.

The KMB 18A/B and KMB 28 use a stud (93) and a machine screw (25) to mount the side block assembly (120a/b).

The nut (20), lock washer (19), and flat washer (18) bed solidly on the interior of the mask frame (17) wall securing the side block assembly (120a/b). Both sources of gas flow through the same passage in the side block body (94a/b) to two exits. One exit is always open to supply gas to the demand regulator assembly (63a/b). The other exit is to the defogger valve (free-flow valve) assembly (83 through 92).

The diver controls the flow of gas through the defogger system with the control knob (85). The flow enters the mask and flows through the air train (21) which directs the gas onto the face port (27) to prevent fogging that forms there from the

diver's warmth and moisture. The flow continues out through the mask main exhaust (66), or into the oral nasal (9) by means of the valve (5), then into the regulator and out through the regulator exhaust (62). The diver can breathe from this flow of gas if the demand regulator malfunctions.

Returning to the side block assembly (120a/b): the other passage for gas is to the regulator (63a/b). It goes to a hose assembly (117a) on the “A” model or a bent tube assembly (117b) on the “B” model. The flow of gas in the demand regulator assembly (63a/b) is controlled by an automatic valve that supplies gas to the diver on inhalation “demand” only, and shuts off during the exhalation cycle.

The SuperFlow demand regulator (63a/b) senses

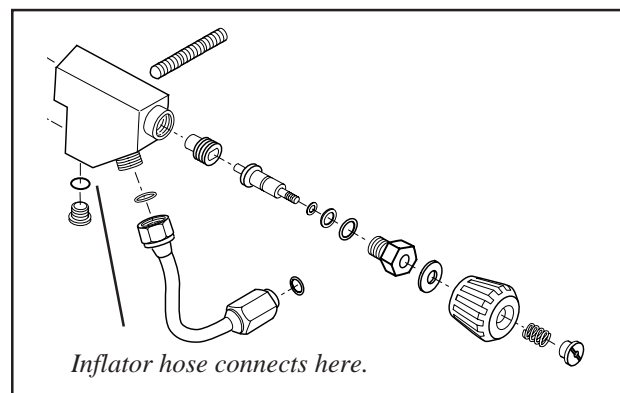

The “B” sideblock allows you to connect a low pressure hose to your dry suit.

the start of the divers inhalation and opens the flow valve, matching the diver's need. The regulator continues to match the diver's inhalation as the rate increases, peaks, then ebbs and stops. When the diver exhales, the supply gas stays off as the exhalation gas flows through the regulator body (39), out the regulator exhaust valve (62), through the whisker (35), and out into the water. The whisker (35) deflects the exhaust bubbles away from the face port (27) to keep the diver's view clear.

All Kirby Morgan Helmets and Bandmasks are equipped with a multi turn demand regulator adjustment knob. The purpose of this adjustment knob is to allow the diver the ability to compensate for variations in umbilical supply pressure. This adjustment device operates by simply increasing or decreasing the amount of spring bias tension on the demand regulator inlet valve. The adjustment knob has a range of approximately 13 turns from full in to full out. The intent of this bias adjustment device is strictly to allow the diver to make adjustments for variations in umbilical supply pressure. This adjustment device is not intended as a minimum-maximum device. Minimum and maximum applies to supply pressure only. The adjustment knob should be adjusted by the diver to be at the easiest breathing setting at all times. The exact number of turns required is dependent on the supply pressure. Diving a KMDSI helmet or bandmask with a bias setting greater than that just necessary to keep the demand valve from free flowing increases the work of breathing and reduces the diver's ability to perform heavy work.

The adjustment knob (47) allows the diver to control the regulator for a wide range of incoming gas pressures. Normally, this would be from 115 P.S.I. to 225 P.S.I. over ambient (diver) pressure. It is important to have this control at the diver for the least breathing resistance.

The Kirby Morgan Band Mask 18B and KMB 28 side block is drilled and tapped to accept low pressure inflator hoses. This allows the diver the capability to inflate variable volume dry suits or buoyancy compensators. It is tapped with a 3/8"-24 thread orifice, standard for American first stage scuba regulator low pressure auxiliary fittings. The port is shipped plugged at delivery.

 **WARNING:** When using the side block low pressure inflator port. The Operator should only use high quality hoses with an integrated flow restrictor or a KMDSI flow restrictor PN# 555-720. All hoses must have an in-line restrictor to reduce the gas flow in the event of hose failure. Do not use fitting adapters, standard adapters do not provide an adequate flow restriction. The use of many off the shelf adapters on the side block assembly could expose the low pressure hose fittings to excessive stress. Any failure of an inflation hose will subject the diver to a decreased supply pressure.

1.5.2 Auxiliary Gas Supply System

All divers using Kirby Morgan surface supplied helmets and masks must always have a diver worn auxiliary gas cylinder fitted with a first stage regulator and hose that is connected to the inlet of the auxiliary supply valve (103). The size of the cylinder should be such that will allow the diver to safely ascend to the surface or to a point where the normal gas supply can be restored. The first stage regulator should always be fitted with the KMDSI overpressure relief valve.

 **WARNING:** Be sure the auxiliary air/gas first stage regulator is fitted with an overpressure relief valve. A leaky first stage can overpressure the hose, bursting it and causing a loss of the entire auxiliary air/gas supply and possible physical injury to the diver as the hose whips about. Do not use a high pressure hose as the system on the helmet is not designed for high pressure.

The KMDSI Overpressure relief valve, part number 200-017, has been manufactured in two different flow rates. The original valve had a lower flow rate than the current valve. The current valve has been marked in two ways, the first being a groove around the flats of the hex. Currently the valve is marked with a groove around the top of the body. These are the same valve, just different marks.



Shown are the three versions of the over pressure relief valve

! DANGER: Your auxiliary air/gas supply on a deep mixed-gas dive is extremely limited. All divers must be aware of exactly how long their bailout bottle will last at depth. For example, a diver breathing one cubic foot of air a minute at the surface will use a 50 cubic foot bailout bottle in approximately 7 minutes at 198 FSW while at rest.

1.5.3 Reducing Carbon Dioxide

It is important to reduce the internal volume of the mask that the diver is breathing through. Carbon dioxide (CO₂) can build up if proper flushing does not occur. A rubber oral nasal mask (9) is located inside the mask to fit over the diver's nose and mouth. The oral nasal (9) attaches to the regulator mount nut (8). This separates the breathing gas flow from the larger gas space on the interior of the mask, and this in turn reduces carbon dioxide buildup.

! WARNING: Always be sure the oral/nasal valve is properly mounted in the oral nasal mask. If the valve is mounted improperly or absent this can lead to a higher CO₂ level inside the mask. A higher CO₂ level can cause dizziness, nausea, headaches, shortness of breath, or black-out. This can also increase the probability of decompression sickness. The correct flow of gas is from the mask into the oral nasal.

! DANGER: Do not confuse the oral/nasal valve with the main exhaust valve. They are not the same thickness. The main exhaust valve is much thicker. Using the main exhaust valve in the oral nasal valve body will restrict the air flow to the diver. Using the oral nasal valve in the main exhaust could cause water to leak into the mask.

1.5.4 Main Exhaust System

The main exhaust system (64,65,66,67) is located at the bottom of the mask frame (17). Breathing gas exiting through this valve automatically purges water from the interior of the mask. This happens naturally because the valve (66) is the lowest part of the mask during normal working or swimming conditions. The cover (65) may be removed by unscrewing the two screws (64). Removal of the cover (65) permits access to the rubber mushroom valve (66). The main exhaust body (67) on the KMB 18 is held in place by three screws (69). (Note: The main exhaust body is molded directly into the mask frame on the KMB 28.)

The rubber mushroom valve (66) is designed to present a resistance to the flow of exhaust gasses. This is necessary to prevent the demand regulator (63a/b) from turning on a steady flow when the diaphragm (52) is positioned lower than the main exhaust (66) during a dive. The diver does not encounter this resistance as he exhausts out of the regulator exhaust.

1.5.5 Communications

The Kirby Morgan Band Mask (KMB 18A/B and 28) communications system is very simple. For two wire (push to talk) communications systems, the left earphone (11) with the longer wire, and the right earphone (10) with the shorter wire, are wired in parallel with the microphone (12) to the communications posts (73). These posts (73) are also known as “bare wire” connectors. The wire that is part of the umbilical bundle is connected to these connectors.

The KMB 18A/B & 28 may also be fitted with a waterproof connector (80). This system comes standard with a terminal block (82) that is used with four wire communications, also known as “round-robin” systems. The terminal block can also be wired for two wire systems if preferred.

Electrical signals are sent to, and received from, the surface through the umbilical wires. An amplifier boosts the signals to the desired volume for the surface and the diver. The diver is always “on” in a two wire system, except when the tender pushes a switch to talk to the diver. In a four wire system, both top side and the diver can speak at the same time, just as you would on a telephone.

1.5.6 Hood and Face Seal

The hood and face seal (2) is fabricated from foam neoprene and open cell foam. The open cell foam forms a comfortable cushion that pushes the sealing surface of the foam neoprene against the diver’s face.

The hood incorporates built-in pockets that are open to the interior of the mask frame (17). These pockets retain the earphones (10,11). It is very easy to remove the earphones for maintenance.

If the standard hood does not fit your head comfortably, other sizes are available from your KMDSI dealer.

1.5.7 Hood and Face Seal Retainer Bands (15, 16, 68) and Band Keepers (121, 123)

The top band (16) and the bottom band (68) fit around the hood and face seal combination (2) and clamp it firmly to the mask frame (17). Two screws (15) tighten these bands in place. The patent pending Band Keepers™ (121, 123) coupled with the redesigned hood, not only prevent any separation of the hood from the mask but also makes it impossible for the bands to separate from the mask. Five spider “hooks” consisting of stainless steel posts welded to the retainer bands (16,68) are located on the top and bottom bands. The top band (16) has three stainless steel posts. The bottom band (68) has two stainless steel posts.



DANGER: The bands must be tightened properly or the mask frame may separate from the hood and face seal. If this happens the diver can drown and death may result.

1.5.8 Head Harness or “Spider”

The five legged head harness or “spider” (1) is a simple and convenient method of keeping the mask in place against the diver’s face. The multiple holes punched in each leg allow adjustment to fit any size head. It will be more comfortable if the lower rear or neck area is as low as possible on the diver’s neck. If this lower portion of the spider (1) is too high, it will cause the face seal to push up on the chin causing discomfort.

1.6 IMPORTANCE OF PROPER MAINTENANCE

Although the Kirby Morgan Band Mask KMB 18A/B is a rugged piece of equipment, proper care and maintenance is essential. The demand breathing system is simple in design but subject to malfunction if not properly maintained. Normal wear requires periodic internal adjustment to the regulator. This will assure the diver of easy breathing.

! DANGER: Without correct, regular maintenance, your mask will not function properly. A poorly functioning mask can cause a fatal accident.

! WARNING: When purchasing spare parts, always insist on Kirby Morgan Genuine Parts. Although other parts may look the same, they may not be manufactured to the same standards of quality. Improperly manufactured parts can cause accidents.

1.6.1 Special Tools

A Regulator Adjustment Tool Kit (KMDSI Part #525-620) containing four special adjustment tools is available for internal adjustment of the demand regulator assembly (63a/b). These tools make regulator adjustment much easier. The tool kit comes in a convenient, wallet sized pouch with instructions.



CHAPTER 2

OPERATING INSTRUCTIONS

2.1 INTRODUCTION

This section provides the manufacturer's advice on how to use the Kirby Morgan 18A/B and 28 Band Masks. The use of these diving Band Masks will vary with the type of work and environmental conditions.

 **DANGER:** The basic procedures of donning and removing the Kirby Morgan 18A/B or 28 will be similar for every job. A proper training program in a calm, clear body of water must be undertaken. If the diver has not used the Kirby Morgan 18A/B or KMB 28 before, he must not go on a job without proper training. Death could result due to a lack of familiarity with the mask.

Divers that are familiar and trained in the use of previous mask designs of Kirby and Morgan (Models 8, 9, 10, the Navy MK. 1, the SuperLite-17A/B, or the SuperLite-27) will find the Kirby Morgan 18A/B and 28 to have the breathing system controls located in the same position and the operation of the Band Mask will be similar.

The numbers appearing in parentheses are "location" numbers on the parts list, which appear on the "blowpart" illustration at the end of this manual. You should fold out the blowpart illustration to view while you read this section.

2.1.1 First Use of Kirby Morgan 18A/B & 28

When you first receive your Kirby Morgan KMB 18A/B or KMB 28, carefully unpack it and examine it for any damage that may have occurred during shipment. Use the inspection sheet provided to ensure that no damage has occurred during shipment. The purchaser must contact the freight carrier and/or the KMDSI dealer if the Band Mask has been damaged in shipment.

Be sure to complete the enclosed warranty card and return it to KMDSI immediately. No warranty claims will be honored without a satisfactorily completed warranty card on file at KMDSI. The card enables KMDSI to know what unit you have so we can contact you in the event of a safety notice being issued for this product. It is your responsibility to keep the factory notified of any change of address you may experience.

 **CAUTION:** It is the responsibility of the end user to register their ownership of this mask with Kirby Morgan. If the mask is not registered KMDSI has no way to contact you regarding product upgrades.

WARRANTY INFORMATION

Kirby Morgan Dive Systems, Inc. warrants every new mask, helmet, or Dive Control System (DCS), to be free of defects in workmanship for a period of ninety (90) days from date of purchase. This warranty covers all metal, fiberglass, and plastic parts. This warranty does not cover rubber parts, communications components, or Band Mask hoods.

Should any part become defective, contact your nearest authorized KMDSI dealer for a replacement.

This warranty becomes null and void if:

- 1) The product is not registered with KMDSI within ten (10) days of purchase.
- 2) The product has not been properly serviced and maintained according to the appropriate KMDSI manual.
- 3) Unauthorized modifications have been made
- 4) The product has been abused or subjected to conditions which are outside normal diving conditions or exceed the product's intended service.

2.2 PRE DRESS-IN PROCEDURE

Before dressing in for a dive, inspection of the Band Mask system must be made to be sure it is in proper working order. This must be done well in advance of the dive, so any problems can be fixed without delaying the dive. The following steps are part of the recommended daily maintenance which is also in Section 4.1.

2.2.1 Pre-Dive Inspection

Inspect the exterior and interior of the Band Mask.

- 1) The demand regulator cover assembly (51) must not be dented.
- 2) Inspect the regulator hose assembly (117a) on the “A” model, and the bent tube assembly (117b) on the “B” model. There must be no dents or kinks in the bent tube assembly. The hose assembly must be in good shape.
- 3) Inspect the face port (27). It must be in good condition.
- 4) Check the inside of the Band Mask. Be sure the communications wires are hooked up and there are no loose nuts. Check the wire lugs to make sure they are not touching each other. This would cause a short (no communications).
- 5) Inspect the oral nasal mask (9). Make sure it is on the regulator mount nut (8) properly.
- 6) Check the screws (29) on the port retainer (28). They must be adjusted to the proper torque setting (12 inch pounds (13 kg cm)) per the specifications in Appendix 1 of this manual. Binder head screws are used in this application for their self locking characteristics. Overtightening will strip out the threaded inserts in the Band Mask frame (17).

 **DANGER:** All parts on the Kirby Morgan 18A/B must be adjusted to their proper torque specifications. See Appendix 1 for a complete listing of torque specifications for each part. Failure to adjust parts to the recommended specifications could lead to Band Mask failure and accidents. This could be fatal.

 **DANGER:** Never use RTV to glue on the port retainer or to hold the threaded inserts in the mask if they are loose. If the RTV fails it could cause the mask to flood and lead to drowning. This can be fatal.

7) Check the spider (1) to ensure there are no tears or cracks in the material. If the spider is worn or cracked it must be replaced. All five “legs” of the spider must be present.

 **DANGER:** The spider must be in good condition. If it is worn or cracked it could fail during the dive. This could cause the mask to flood or come off the diver’s head. This could lead to drowning.

8) Check the hood and face seal (2). The hood must be in good condition with no tears or rips. The face seal must be properly glued to the hood. If it is not, or there are tears in the face seal this will cause the regulator to free flow.

 **CAUTION:** A torn face seal will cause the regulator to free flow. This could lead to a rapid consumption of the diver’s air supply if bottled breathing gas is being used.

9) Check the screws (15) that hold the bands (16 & 68) in position. They must be adjusted to the proper torque setting (see torque specs pg. 89) When the screw are adjusted properly, the hood and face seal cannot be moved from under the bands.

10) Be sure to inspect the bands themselves (16 & 68). The welds must show no signs of cracking or parting.

! DANGER: If the bands become loose the hood and face seal could separate from the mask if no BandKeepers™ are installed. This would cause the mask to flood which could cause drowning.

2.2.2 Clean Face Port (27)

Remove any sand or dirt on the interior of the face port (27) which might cause scratches when anti-fogging solution is applied prior to the next dive.



Fig. 2.1 Clean the face port prior to use.

2.2.3 Check Moving Parts

Check all moving parts, such as the regulator adjustment knob (47), the defogger control knob (85), auxiliary knob (100), and the nose block device knob (34) to ensure smooth and proper operation.



Fig.2.2 Moving parts, such as the regulator adjustment knob must be checked before the Band Mask is put on line.

2.2.4 One-Way Valve (104) Check

There are two ways to check the one-way valve (104). Check both ways if possible.

1) Leaving the auxiliary knob (100) open (on) and not hooked up to the supply hose, try to suck air out of the adapter (105). If any air comes out, the one-way valve must be replaced.

! WARNING: The one way valve must be tested daily, prior to commencement of diving operations. Failure of the one way valve could cause serious injury or death.

KMB 18 & 28 MANUAL

2) Prior to attaching (or pressuring up) the umbilical, close the auxiliary valve (103), and attach and pressure up the auxiliary hose. Shut off the defogger control knob (85) and screw in the adjustment knob (47) on the regulator all the way. With the auxiliary hose pressurized, turn on the auxiliary valve knob (100). If any gas escapes out the adapter (105) or (if attached) into the unpressurized umbilical hose, the one-way valve (104) is faulty and must be replaced. Flow into the unpressurized umbilical hose can be heard. A one-way valve repair kit is available for rebuilding these valves (KMDSI Part # 525-330). Contact KMDSI at (805) 865-8538 if you have any questions regarding rebuilding your one-way valve.



Fig. 2.3 Always check the one-way valve prior to diving.

⚠ WARNING: Never dive if the one-way valve is not operating properly. If the hose breaks near the surface a serious injury could result to the diver's lungs and/or eyes. In extreme cases this could be fatal.

2.2.5 Connecting the Band Mask to the Diver's Umbilical

When you connect the hose to the Band Mask, be sure to use a wrench to hold the adapter, or inlet fitting, (105), and a second wrench to turn the fitting on the hose. If this is not done, the adapter (105) will turn inside the one-way valve (104). If this happens repeatedly the threads will wear and the valve will need to be replaced. The connection between the hose and the Band Mask must only be made up "snug". Excessive force will deform and ruin the adapter (105). A second wrench must be used when the Band Mask is disconnected as well, otherwise the adapter (105) and/or the one-way valve assembly (104) may become loose and fail to make a seal. If this happens it is necessary to remove the adapter, clean off all the thread tape, and reseal it using Teflon tape.



Fig. 2.4 Always use two wrenches to connect the umbilical to the KMB 18A/B or 28.

If you are using waterproof connectors for your communications (13), take extra care in handling these pieces. To connect the male (80) and female parts, align the large pin on the male connector (80) with the yellow mark on the female connector. Press the two connectors together until you hear a distinct “pop”. **Do not twist the connectors.** Tape the two connectors with a bit of electrical tape to prevent them from pulling apart.

To separate the connectors remove the tape, grasp them at the thickest part, place your thumbs against each other, and push apart until the connectors are disconnected. **Do not twist the connectors or pull them apart while holding onto the thinner wire.**



Fig. 2.5 Tape the two mating waterproof connectors together with electrical tape prior to diving.

2.2.6 Gas Flow Systems Check

If the regulator adjustment knob (47) is screwed out all the way, in its storage position, screw it in all the way. The umbilical air, or gas supply is turned on pressurizing the side block and regulator. Now unscrew the regulator adjustment knob (47) until a slight steady flow is present, then turn it back in until it just stops.



Fig. 2.6 Screw in the regulator adjustment knob prior to turning on the diver's breathing gas.

To check the breathing system correctly, open the zipper and don the Band Mask by holding it firmly against your face. Test the defogger system by turning on and off the defogger control knob (85). The regulator (63a/b) should be adjusted by turning the adjustment knob (47) out until a slight steady flow starts, then back in until the flow just stops. Next, the demand regulator system (63a/b) is checked for proper function: breathe in and out. Inhalation and exhalation effort should be nearly unnoticeable. Press in on the purge button (51d) in the regulator cover (51b). A strong burst of gas should follow.



Fig. 2.7 Always test the breathing system prior to diving.

2.2.7 Sealing Integrity Check

If there is any doubt whether or not the Band Mask is sealing properly, perform the following test prior to diving.

Turn the supply gas off at the dive control system and bleed the umbilical. Pull the nose block device knob (34) all the way out, away from the mask. Have the diver install the mask on his/her face, but ***do not fasten the hood. Do not fasten the head harness (spider).*** With the mask held firmly against his/her face, there must be a suction on the diver's face when he/she inhales. This will indicate that the mask is forming a good seal. If there is any leakage the diver must not dive until the source of the leakage has been found and corrected.

⚠ DANGER: If a good seal is not present, the breathing system will not work properly. In addition, the mask may flood with water, causing drowning and/or death. It is the diver's responsibility to make sure a good seal is present.

2.2.8 Check Communications

Check the communications system for proper operation. Put the Band Mask on and talk to an assistant on the amplifier. If you are by yourself, take the Band Mask near the amplifier and tap on each earphone and the microphone, listening to the taps on the amplifier/speaker. Talk into the amplifier/speaker feeling the vibration on each earphone and the microphone with your fingertips.



Fig. 2.8 Always check the communications with the mask prior to each dive.

2.3 Diving Procedures

2.3.1 Fogging Prevention

A thin film of anti-fogging solution must be applied to the interior of the face port (27) to prevent fogging during the dive. A liquid dish washing detergent such as "JOY" must be applied with a soft rag or paper towel to the interior of the port. Other anti-fogging solutions are commercially available. The diver should use whatever solution he has found satisfactory in the past. However, do not use an aerosol spray on the lens. The propellants in some aerosol dispensers cause damage to the port.

⚠ DANGER: Never use any aerosol propelled sprays near the face port of the Kirby Morgan 18A/B and 28. The Freon propellant used in these aerosols can invisibly damage the face port and cause it to shatter upon impact from any strong blow. If the face port fails underwater the Band Mask will flood and drowning may result.



Fig. 2.9 A thin film of liquid detergent should be applied to the mask lens prior to diving.

2.3.2 Flushing Out The Umbilical

Before connecting the umbilical to the mask, the umbilical must be flushed out to remove any dirt, moisture, or other debris.

Connect the topside umbilical end to the topside diver control console. Insure there is no pressure in the divers umbilical. Carefully uncap the mask end of the umbilical and hold securely while pointing in a safe direction, then slowly bring up gas pressure to approximately 25-40 psig (1.7-2.7 bar). Allow the gas to flow for at least 15 seconds, then secure. If the mask is not going to be used immediately, it should be recapped.

2.3.3 Auxiliary Gas System

If the divers main gas supply fails, the diver must have another source of gas that will enable a safe return to the dive station or to a point where a normal gas supply can be reestablished. For this reason an auxiliary gas supply (bail out) cylinder must be used on all dives. The bail out cylinder is normally worn on the back using a combination backpack and lifting harness. In some cases divers wear a lifting harness with an independent backpack for securing the auxiliary gas cylinder. Regardless which configuration is used, a good quality lifting harness should always be worn by the diver. The harness provides an attachment point where the umbilical can be secured to the diver and a secure lift point when removing an injured or unconscious diver from the water.

An auxiliary bail out cylinder must be used for all diving operations. In some cases, a very small auxiliary bail out cylinder is mounted horizontally across the lower rear or front of the torso. Selection of the size of the cylinder is usually

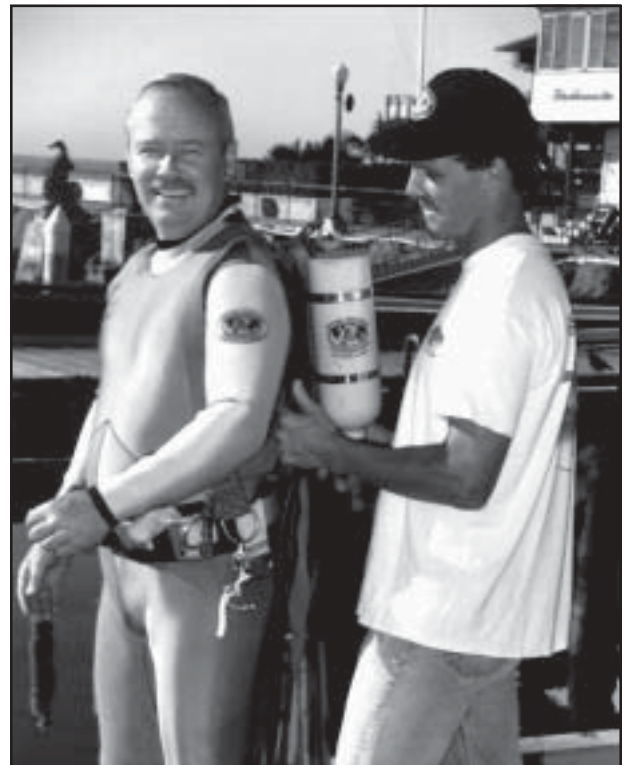

Fig. 2.10 The diver must always wear a bail-out bottle.

KMB 18 & 28 MANUAL

determined by the hazards associated with the diving job. When determining the size of the auxiliary gas cylinder to be used, several factors must be considered. The divers depth, the length time the diver may be without the main gas supply, and the gas consumption rate. Regardless of the cylinder used, it should be of sufficient volume to allow the diver to ascend at a normal rate or transit to a point where a normal gas supply can be reestablished.

European C.E. ONLY

In European countries that have adopted C.E. certification, only C.E. certified cylinders are allowed to be used and must have a minimum charged capacity available to the diver of 1400 Nl (50 scf). The auxiliary gas supply must only be fitted with a KMDSI first stage regulator and have a KMDSI over pressure relief valve installed (Part # 200-017). The relief must be adjusted to start lifting at approximately 20 psig (1.4 bar) above the regulator intermediate setting. The purpose of the relief valve is to allow pressure to vent off in the event the first stage regulator develops a leak or creeps. Without a pressure relief valve, the hose could rupture and the auxiliary gas supply would be lost.

Most commercial divers wear a harness (separate from the weight belt) that is used for several purposes. The harness is fitted with large metal rings (usually brass or stainless steel). The umbilical is hooked into one of these rings to keep any strain off the helmet. In addition, the rings on the harness are used to hang tools and other equipment. Usually the harness is also designed to provide a means of lifting an unconscious diver from the water. This harness is the best method of securing the auxiliary breathing gas to the diver.

⚠ DANGER: Never dive without a bail-out bottle. If your topside supply is interrupted for any reason you will have nothing to breathe. The bail-out must be matched to the water depth and filled with the appropriate breathing gas.



Fig. 2.10 A typical commercial diving harness.

The compressed air (or gas) tank must be fitted with a first stage regulator to reduce the pressure to less than 225 P.S.I. ambient diver pressure. The Band Mask cannot properly handle more pressure without modification. The CE approved D.S.I. SuperFlo[®] first stage Scuba regulator (Part #305-161) is the best device for this use. These regulators reduce the tank pressure to about 145 P.S.I. Use a D.S.I. Scuba regulator hose fitted with a quick disconnecting locking sleeve (Part #255-020) to the auxiliary valve assembly (103) located on the side block (94a/b). The 18A side block (94a) requires a slightly longer hose such as used on “octopus” Scuba regulators. Other high performance scuba first stage regulators may also be used.



Fig. 2.12 Only a high performance scuba first stage , such as the CE approved KMDSI first stage part #305-161, must be used with the bailout bottle.

The first stage regulator must have at least two low pressure ports. One port is used for the connector hose to the auxiliary valve and the second is used to install an overpressure relief valve (Part #200-015). If the first stage develops a leak, the full pressure of the tank could be placed on the low pressure hose. This could cause the hose to burst. The overpressure relief valve will bleed off any leak.

Never connect the high pressure hose directly to the auxiliary valve assembly (103), as this will transmit the full pressure of the tank to the side block (94a/b). The side block (94a/b) is not designed to handle high pressure. A standard Scuba submersible pressure gauge must be connected to the high pressure port on the first stage so that the diver can monitor his/her auxiliary supply.

The diver, at a minimum, should have his/her suit, harness, and tank of auxiliary gas in place prior to connecting the quick disconnect hose for the auxiliary supply.

Make sure the auxiliary valve knob (100) is turned off, otherwise the auxiliary gas supply will be used up without the diver's knowledge. Once the auxiliary supply hose is connected, the tank valve is turned on to pressurize the hose. In the event of an auxiliary due to a loss of the main gas supply, the auxiliary valve knob (100) located on the side block (94a/b) is turned on, supplying gas to the side block system (120a/b) and the demand regulator assembly (63a/b).

WARNING: Never connect the main gas supply hose from the diving control station to the auxiliary valve (103). If this is done there is no one-way valve protection for the diver in the event of damage to the umbilical or related equipment. The diver could be exposed to a serious "squeeze".



Fig. 2.13 The use of a quick disconnect fitting makes diving operations easier.

2.3.4 Securing the Band Mask on the Diver

All donning procedures should be done by the diver alone to train for familiarity with the equipment. The breathing gas supply should be on before the diver dons the mask. Everything else must be ready to go before the diver puts the Band Mask on so he won't have to support the weight of the Band Mask while out of the water.

To prepare the mask for donning by yourself, close the zipper until only the last six inches are open. Fasten every "leg" of the spider (1) except the one on the bottom left.

Pick the mask up with both hands and fold the spider over the front of the mask. Pull the hood onto your head and close the zipper, taking care not to catch your hair in the zipper. You will need to support the mask with your right hand as you do this. Use your left hand to close the zipper. While you continue to support the mask with your right hand, use your left hand to fasten the remaining leg of the spider to your left. As a standby diver, it is essential for you to be able to don your mask yourself during an auxiliary.

For most divers, the mask is most comfortable when the spider is adjusted so that the top three legs of the spider are tighter than the bottom two. If you have an "average" size head, the adjustment most divers find comfortable is three holes



Fig. 2.14 Preparing the mask for donning by yourself.



Fig. 2.15 You must be capable of donning your Band Mask by yourself.

back from the edge of the top three legs of the spider, and two holes back from the edge of the outermost two legs of the spider. If you have a smaller head, the mask will need to be tighter and if you have a larger head it will need to be looser.

The mask should feel comfortably snug against your face out of the water. There will be some compression of the face seal when it is adjusted properly. While the weight of the mask is heavy out of the water, it will be almost unnoticeable underwater.



Fig. 2.16 Your tender may also assist you in closing the zipper and fastening the spider.

Your tender may assist you in donning your mask if you prefer. In this case, the procedure is the same as donning by yourself, except that your tender will close the zipper on the hood and fasten the spider. You will still need to support the weight of the mask while your tender fastens you in.

To help keep the bib of your hood from floating up, you may want to tuck the bib of the hood under your harness.



Fig. 2.17 To keep the bib of the hood from the mask from floating up, it may be tucked underneath the straps of your diving harness.

2.3.5 Attaching the Umbilical to the Harness

The umbilical must now be hooked to the diver's harness by means of a suitable clip that is bound to the umbilical. Some divers and companies prefer a quick release clip and others prefer a clip that is screwed together so the diver cannot easily remove it from his/her harness. The securing of the umbilical keeps the pull of the hose on the diver's harness and not on the Band Mask.



WARNING: Never dive without attaching the umbilical to some type of harness or clip on the diver's body. Never allow the umbilical to pull on the Band Mask directly, or the diver could suffer a neck injury or the mask could be pulled off his/her head.



Fig. 2.18 The umbilical must always be attached to the diver's harness with some type of clip to prevent a direct pull on the diver's mask.

2.3.6 Diver Check Gas Flow Systems

The diver must check out the breathing system himself as the tender finishes dressing him. Operate the defogger valve, the auxiliary valve, the demand regulator, and the purge button to assure yourself of proper operation before entering the water.

2.3.7 Communications Check

The communications system, sending and receiving, must be checked again at this point.

2.3.8 DIVER READY

The diver is now ready to enter the water. He must be assisted to the water if needed. If a welding lens is being used, make sure it is hinged up all the way if the diver is making a jump entry to avoid any damage to the mask. A quick overall inspection by the tender is done and the diver is given the O.K.

2.3.9 Water Entry and Descent

The tender must make sure there is a sufficient length of umbilical clear if the diver is using a jump entry. There must be no chance of the umbilical hanging up when the diver jumps. Also, the defogger valve should be turned on to over-pressure the helmet to prevent the possibility of water pressure from inverting the helmet exhaust valve when hitting the water.

The diver must report to the surface immediately after the entry. It is a good policy to descend 10 or 20 FSW (3-6 MSW), pause and check the regulator adjustment knob to ensure adjustment for the least breathing resistance. *(The purpose of this adjustment knob is to allow the diver the ability to compensate for variations in umbilical supply pressure. This adjustment device operates by simply increasing or decreasing the amount of spring bias tension on the demand regulator inlet valve. The intent of this bias adjustment device is strictly to allow the diver to make adjustments for variations in umbilical supply pressure. This adjustment device is not intended as a minimum-maximum device. Minimum and maximum applies to supply pressure only. The adjustment knob should be adjusted by the diver to be at the easiest breathing setting at all times. Diving a KMDSI helmet or band mask with a bias setting greater than that just necessary to keep the demand valve from free flowing increases the work of breathing and reduces the diver's ability to perform heavy work.)*

Then the diver checks in with the surface before descending to the job. If a closed bell is being used, the diver enters the water from the bell and pauses for a short time outside the trunk until he is sure all systems are operating properly.

During the decent the communications must be checked again and the diver supply pressure should be adjusted as necessary to maintain the required over-bottom pressure. It may be necessary for the diver to readjust the demand regulator by means of the adjustment knob (47) once at the work site to compensate for the variation in umbilical supply pressure.

2.4 EMERGENCY PROCEDURES

2.4.1 Flooding

In the event of partial or complete flooding, the diver may clear the Band Mask quickly by getting the Band Mask in an upright position (normal swimming or working position) and activating the defogger control knob (85) or by pressing in on the manual purge button (51d) in the center of the regulator cover (51b). Tilt your head forward to clear the Band Mask more quickly using the water dump valve (66). The opening in this valve is much larger than the opening in the regulator exhaust valve (62). After clearing, cautiously check for additional flooding. If the Band Mask continues to take on water, return to the diving station, swimming face down with the free flow knob on.

2.4.2 Inhalation Resistance

If breathing becomes difficult, adjust the demand regulator adjustment knob (47), for easier breathing by rotating the adjustment knob counter clockwise. If the breathing does not get noticeably better press the purge button in the regulator cover (50). If a surge of gas does not flow with this action, open the auxiliary valve (103). If the flow is noticeably better, immediately notify topside that you are on auxiliary gas. Insure your umbilical is clear and return to the stage or decent line. The diver should stay in communication with topside personnel and make preparations to abort the dive. The console operator should check to ensure the supply pressure to the diver is at the proper pressure.

2.4.3 Gas Flow Stops

A stop of flow in the demand regulator system usually indicates the main gas supply has stopped. The diver must first open the auxiliary valve by turning the knob (100). If there is still no flow from the demand regulator, the defogger valve should be opened. **CAUTION: if the defogger valve is left open, the bail out bottle will drain very quickly, particularly if the diver is deep.**

Immediately return to the diving station using the auxiliary breathing supply. If the diver is working near the surface the weight belt may be dropped to speed ascent.



DANGER: Rapid ascents are dangerous. Even on a no decompression dive, a rapid ascent may cause decompression sickness. A diver should only make a rapid ascent when he is in immediate danger of death by drowning or asphyxiation.



DANGER: Ditching the Band Mask underwater must be avoided. If the diver ditches the Band Mask underwater he will not be able to see. In many instances, even if the air supply is interrupted, topside will be able to get it back on line quickly. Do not ditch the Band Mask underwater unless you are completely out of breathing gas and it is impossible to return to the surface due to entanglement of your equipment or similar circumstances.

If an open bottom bell is used it should be positioned as close as possible to the diver. The diver's hose must be fed through the bell stage so that the diver can find his/her way back to the bell if necessary. The top of the open bottom bell must be filled with the correct breathing gas for the diver's depth. In addition, the bell must be equipped with communications.

KMB 18 & 28 MANUAL

2.4.4 Demand Regulator (63a/B) Free Flow

If the demand regulator free flows, adjust the knob (47) in (clockwise) until it stops. If it cannot be stopped, and the free flow is strong, the dive should be stopped. Even if there is no serious problem to the diver, communications will be very poor.

2.5 POST DIVE PROCEDURES

2.5.1 Removing the Equipment

After the diver is well clear of the water he may remove the Band Mask. If the diver is working out of a stage he must not remove the Band Mask until the stage is on deck.



Fig. 2.20 The diver should be capable of removing the Band Mask by himself.

The diver can shed the Band Mask by grasping the bottom of the mask with both hands and pushing out and up. The mask can be removed in the event of an emergency in this way even if the zipper is closed and the spider is in place.

! WARNING: Never remove the diving Band Mask while you are in the stage. If you fall out of the stage with the Band Mask off but still attached to your harness it may be very difficult to swim. Drowning may result.



Fig. 2.21 The tender may assist the diver with the removal of his/her equipment.

Under normal circumstances, a good tender will be prepared to help the diver with the removal of the Band Mask as required. The diver should support the weight of the mask as the tender opens the zipper on the hood (2) and unfastens the spider (1).

It is recommended that during normal diving operations that only the left side of the spider be opened. Complete removal is not necessary. This will help prevent loss of the spider.

Turn the auxiliary gas supply off at the tank. The auxiliary gas supply hose may be disconnected while the diver leaves the Band Mask on, or while he holds it after removal. The quick disconnect makes this procedure very easy. The tender should then unfasten the umbilical from the harness and take the Band Mask from the diver and set it aside. The diver's harness and bailout bottle is then removed.

If the Band Mask is not going to be used for a period of time, the hood (2) must be removed and the earphone covers removed. These parts must be dried before storage. When the Band Mask is completely dry, or the diver is ready to leave the job, the Band Mask must be stored in the carrying bag to protect it. KMDSI's mask bag, Part Number 500-901, is designed for this purpose.

CHAPTER 3

TROUBLESHOOTING

3.1 GENERAL

The Kirby Morgan 18A/B and 28B are highly reliable diving Band Masks which should not malfunction if proper preventative maintenance procedures are followed. Most problems encountered in using the Band Mask can be easily remedied. The following information covers most potential operating difficulties.

3.2 COMMUNICATIONS MALFUNCTIONS

Symptoms	Probable Cause	Remedy
No sound at either com box or Band Mask	Communication box not on.	Activate switch and adjust volume.
	Communications incorrectly hooked up.	Switch terminal wires.
	Communications not hooked up.	Plug into terminals.
	Communicator not functional.	Replace communicator.
Communications weak or broken up	Terminals in Band Mask covered with corrosion. Low battery in communicator.	Clean terminal with wire brush until metal is bright and shiny. Charge or replace battery in communicator.
Communications only work when wire is wiggled back and forth.	Break in diver's communication wire.	Splice wire if damage is minor. Replace wire if damage is major.
Communications only work when connector (80) is wiggled back and forth.	Break in waterproof connector (80)	If connector (80) is suspect, remove from line and test line for integrity prior to replacing connector.
Diver speech weak or not working.	Microphone (12) in Band Mask dead.	Replace microphone (12) as per manual. (Section 6.4.3)
No sound at either communicator or Band Mask.	Communicator not functional	Replace communicator.

KMB 18 & 28 MANUAL

3.3 ONE-WAY VALVE (104) MALFUNCTION

Symptoms	Probable Cause	Remedy
One way valve (104) allows back flow	Foreign matter in valve	Disassemble valve, clean and rebuild. (Section 5.3)
One way valve (104) flow any gas.	Foreign matter in valve	Disassemble valve, clean and rebuild. (Section 5.3)

3.4 SIDE BLOCK (119A/B) MALFUNCTION

Symptoms	Probable Cause	Remedy
Defogger Valve can't be shut off. Mask free flows through the defogger.	Seat assembly (92) damaged.	Replace seat assembly (92) (section 6.10)
Defogger valve will not flow gas.	No breathing gas in umbilical.	Turn breathing gas on to diver's supply topside.
	Foreign matter in side block (94 a/b) or one way valve.	Disassemble side block and clean (section 6.6 & 6.7)
Defogger valve knob (85) hard to turn.	Valve stem (91) bent.	Replace valve stem (91).(section 6.6)

3.5 DEMAND REGULATOR (63A/B) MALFUNCTION

Symptoms	Probable Cause	Remedy
Regulator (63a/b) continuously free flows	Adjustment knob (47) not screwed in.	Screw in adjustment knob (47).
	Supply pressure too high.	Adjust supply pressure lower than 225 P.S.I. (15 bar) O.B.
	Hole in face seal in hood (2),or face seal has separated from mask. Air leaking past face seal causes regulator to flow.	Repair face seal or replace hood.
	Regulator out of adjustment.	Adjust regulator. (Section 5.6)
Regulator is hard breathing.	Adjustment knob (47) screwed too far in.	Screw adjustment knob out.
	Regulator (63a/b) is out of adjustment.	Adjust regulator. (Section 5.6)
Regulator does not supply gas.	Gas supply pressure too low.	Increase supply pressure to minimum of 115 PSI (8 bar) over ambient.
	Regulator (63a/b) is out of adjustment.	Adjust regulator. (Section 5.6)
	No gas in umbilical.	Turn diver's gas supply on topside.
	Blockage in breathing system.	Disassemble regulator, clean, and adjust.

3.6 WATER LEAKAGE INTO BAND MASK

Symptoms	Probable Cause	Remedy
Water Leakage into Band Mask.	Exhaust valve (66) damaged or stuck open	Seat or replace valve. (section 6.13)
	Diaphragm (52) damaged or not seated properly.	Seat or replace diaphragm/ (section 6.14.3)
	Waterproof connector O-ring (74) extruded or damaged.	Replace O-ring. (section 6.6.5)
	Port Retainer screws (30) loose.	Tighten screws (30) to proper torque value.
	Bands (16 & 68) loose or damaged.	Tighten screws (15) to proper torque value. Replace bands if damaged.

3.7 AUXILIARY VALVE (103) MALFUNCTION

Symptoms	Probable Cause	Remedy
Bail out bottle drained without diver opening valve (103).	Stem (96) fails to seat in valve body (95).	Replace valve body (95). (section 6.7)
	Leaking over-pressure valve on bail out regulator	Service valve.
	Leaking bail out regulator on bottle.	Service regulator.
Knob (100) difficult to turn.	Stem (96) bent	Replace stem. (section 6.7)
Valve (103) will not flow gas.	Foreign matter in valve.	Disassemble, clean and reassemble. (sec. 6.7)

CHAPTER 4**INSPECTION/MAINTENANCE TIMETABLE
FOR KIRBY MORGAN 18A/B AND 28 BAND MASK**

Routine and preventative maintenance is critical and must be done on a routine basis. All parts and components of the mask have a useful service life and eventually will require replacement. Some items when properly maintained can go many years before replacement is necessary. It is mandatory that a routine and periodic schedule of maintenance, inspection, and testing be carried out. Chapter 4.0 delineates the recommended minimum maintenance intervals. Masks used in contaminated waters or masks used for welding, burning, and jetting operations must be serviced and inspected more frequently. If a situation arises that casts any doubt as to the serviceability of a part or component it should be replaced. If the user is in doubt about the serviceability or just has questions in general, contact your local KMDSI authorized repair facility or KMDSI at (805)965-8538.

The following service intervals are recommended minimums for Band Masks being used under good conditions. Band Masks used in contaminated water, burning or welding operations, or heavy jetting should be serviced more frequently.

4.1 DAILY MAINTENANCE

See Section 5.4 for details of daily maintenance.

4.2 MONTHLY MAINTENANCE

See Section 5.5 for details of monthly maintenance.

4.3 EVERY SIX MONTHS OR 200 OPERATING HOURS

- 1) Replace inlet valve (59) and nut (53). See Section 6.14.3
- 2) Replace communications set (13). See Section 6.4

4.4 YEARLY OR EVERY 400 OPERATING HOURS

 **DANGER: Each KMB 18A/B or KMB 28 must be inspected on an annual basis by an authorized KMDSI dealer to insure that the threaded inserts that accept the port retainer screws are properly seated in the mask frame. Failure to perform this annual inspection and any required repairs could result in unexpected viewport failure and drowning.**

- 1) Rebuild side block assembly (order side block repair kit, DSI Part #525-311).
See Section 6.5
- 2) Rebuild demand regulator assembly (order regulator repair kit, DSI Part #525-309).
See Section 6.14
- 3) Rebuild one-way valve (order one-way valve repair kit, DSI Part #525-330). See Section 5.5.3.
- 4) Replace communications set (13). See Section 6.4
- 5) Replace whisker rubber (35). See Section 6.12
- 7) Replace waterproof connector (80). See Section 6.4.5.
- 8) Replace O-rings (31, 32, 7, 26, 74). See Section 6.3.3
- 9) Replace oral nasal valve (5). See Section 6.15
- 10) Replace oral nasal (9). See Section 6.15
- 11) Replace hood (2). See Section 5.7
- 12) Test Port Retainer Inserts
(this is a dealer provided service)

CHAPTER 5

PREVENTATIVE MAINTENANCE

5.1 INTRODUCTION

This section covers the preventative maintenance necessary on the Kirby Morgan KMB 18A/B and 28 Band Mask. A Band Mask that is kept clean and in good repair will offer far better service to the user. This Band Mask is designed for easy access to all areas for proper inspection and servicing. Numbers appearing in parenthesis below are "location" numbers that are used in the blow apart illustration at the rear of this manual.

5.2 REQUIRED TOOLS

All Kirby Morgan Dive Systems, Inc. Helmets and Masks are designed with the professional diver in mind. Most maintenance can be performed by the user using common tools and this manual. There are some repairs however, that must be accomplished only by KMDSI authorized repair facilities. This includes fiberglass and face port inserts. For technical assistance please telephone your nearest authorized dealer or call KMDSI at (805) 965-8538.

Every diver should carry sufficient tools and spare parts to maintain his/her Band Mask in top working condition. It is very important to use wrenches of the correct size rather than adjustable wrenches. Adjustable wrenches tend to slip and can round the edges of soft brass parts. The following wrenches and tools are required to maintain the Kirby Morgan 18A/B and 28:

Torque wrench 0-300 inch pounds with the following attachments:

- 1 1/4 inch socket
- 7/16 inch open end wrench
- 9/16 inch open end wrench
- 5/8 inch open end wrench
- 11/16 inch open end wrench
- 3/4 inch open end wrench
- 13/16 inch open end wrench
- 7/8 inch open end wrench
- 1 inch open end wrench

Torque screwdriver with the following attachments:

- 1/8 inch flat blade screwdriver
- 1/4 inch flat blade screwdriver
- 3/8 inch flat blade screwdriver
- #2 Phillips screwdriver
- 5/32 Allen wrench driver

Open end wrenches in the following sizes:

- 3/8 inch
- 7/16 inch
- 9/16 inch
- 3/4 inch
- 7/8 inch
- 1 inch

Two adjustable wrenches 6 and 8 inches in length.
3/8 inch flat blade screwdriver with a notch in the center of the tip.

- 1/4 inch flat blade stubby screwdriver
- 2 needle nose pliers
- diagonal cutting pliers
- 3/32 inch punch
- putty knife
- O-ring removal tool
- KMDSI regulator tools, P/N 525-620
- Silicone grease - Dow Corning MS4 or 111
- Teflon tape, 1/2 inch wide



Fig. 5.1 Always use the correct tools when performing maintenance on your KMB 18A/B or 28.

5.2.1. Component and Parts Cleaning

The mask shell and components should only be cleaned using a mild solution of dishwashing detergent such as JOY® or Dawn® hand dishwashing detergent. Parts that have corrosion should be washed and scrubbed with a nylon bristle brush and then soaked in a solution of 50% white vinegar and water for 30-60 minutes followed by a light brushing and a good fresh water rinse. Hoods and rubber components should be cleaned using a mild soapy solution followed by a good rinsing and air-dried. **DO NOT** use hair dryers or high heat to dry the rubber or fabric components, high temperatures will severely reduce the serviceability of these components. To clean metal parts heavily encrusted with salt we recommend a dilute solution of white vinegar and a toothbrush.

5.2.2 Component and Parts Lubrication

All parts on the mask that require lubrication must be lubricated sparingly with food grade silicone grease. KMDSI recommends Dow Corning 111 or equivalent. If the mask is intended to be used with breathing mixtures greater than 50% oxygen, it should be cleaned for oxygen service, and components requiring lubrication should be lubricated with a suitable oxygen compatible lubricant such as Krytox® or Christo lube®. **DO NOT USE AEROSOL SPRAY LUBRICANTS.** Many aerosol propellants will damage plastic. Avoid lubricant contact with plastic parts.

5.2.3. Teflon Tape

All pipe thread fittings used on the KMDSI helmets, masks and components require sealing with Teflon tape. **DO NOT USE LIQUID SEALANT.** When installing Teflon tape on pipe threads, apply the tape starting two threads back from the end of the fitting. Apply the tape in a clockwise Direction under tension, 1½ wraps is all that is needed. Applying more than 1½ wraps of tape is not recommended. The use of more than 1½ wraps could cause excess Teflon tape to travel into the breathing system.

 **DANGER: Do not allow any excess Teflon tape to enter the breathing system. Loose pieces of Teflon tape can interfere with the performance of the one-way valve or the regulator and may block the diver's air supply. This could lead to death through suffocation.**

5.2.4 RTV Sealant

Certain components used in KMDSI helmets and masks use RTV adhesive/sealant to provide bonding and sealing. KMDSI recommends Dow Corning® RTV 732 multi purpose sealant. Care must be taken to insure excess sealant is wiped clean and does not interfere with other components. Sealant should be allowed to cure for 24 hours before equipment is used.

 **DANGER: All parts on the Kirby Morgan Band Mask 18A/B and 28 must be adjusted to their proper torque specifications. See Appendix 1 for a complete listing of torque specifications for each part. Failure to adjust parts to the recommended specifications could lead to Band Mask failure and accidents. This could be fatal.**

 **DANGER: Never use any aerosol propelled sprays near the face port of the Kirby Morgan Band Mask 18A/B or 28. The Freon propellant used in aerosols can invisibly damage the Lexan® face port and cause it to shatter upon impact from any strong blow. If the face port fails underwater the Band Mask will flood and drowning may result.**

 **DANGER: The standard Kirby Morgan Band Mask 18A/B or 28 is not intended for nitrox or oxygen service as it comes from the factory. If the user intends to use this Band Mask for such service, all parts must be cleaned and lubricated for oxygen service. Only lubricants such as Krytox® or Halocarbon® are acceptable for oxygen service.**

! DANGER: In-water decompression with oxygen is a specialized procedure. All parts of the diving system must be oxygen compatible and cleaned for oxygen service. Any parts of the system (i.e., manifolds, hoses, fittings, etc.) which are exposed to compressed air must be considered contaminated and should not be used again until cleaned for oxygen service.

5.3 GENERAL

Each diver must follow the minimum standards for the care of his/her Band Mask. We offer recommendations here with the suggestion that the diver establish for himself what ever additional service is necessary to provide a good working unit. Use of the Band Mask in fresh water will require a timetable for maintenance procedures different from that when the Band Mask is used in salt water. Using the Band Mask in sea water while jetting in sand will necessitate increased maintenance. Use of the Band Mask in a heavy oil environment or other chemicals will make it necessary to replace rubber parts on a regular basis.

5.4 DAILY MAINTENANCE

The following steps should be performed daily at the completion of diving operations. If your mask has Band Keepers installed, you should not remove the hood from the mask.

1) Disconnect the Band Mask from the diving hose and bail-out bottle. Make sure the air is off and the breathing system of the Band Mask is unpressurized. To vent the system, open the free flow valve knob (85) and auxiliary valve knob (100) until all gas flow stops.

! WARNING: Never disconnect any hose from the Band Mask unless all gas has been vented from the hose first. If the hose is disconnected with pressure in the line the fittings may be damaged. In addition, the hose can whip about causing injury to anyone standing nearby.

2) Place a protective cap over both the air inlet (105) and the auxiliary valve inlet (95) to prevent foreign matter from entering the valves.



Fig. 5.2 Always cap the gas inlet adapter (105) and the auxiliary valve inlet (95) when the mask is not in use.

3) Remove the hood (2) from the mask by unscrewing the band screws (15) and removing the top and bottom bands (16,68). Slide the earphones (10,11) out of their pockets in the hood (2). Remove the earphone covers from the earphones (10,11) so they can dry completely. Avoid getting water on the oral nasal microphone (12) and earphones (10,11), whenever possible.



Fig. 5.3 Remove the hood by unscrewing the band screws.



Fig. 5.4 Remove the earphone covers so the earphones can dry completely.

4) Rinse the Band Mask thoroughly with fresh water. Turn the free flow valve knob (85), auxiliary valve knob (100), and regulator adjustment knob (47) while rinsing to prevent salt from accumulating under these valves. Run water under the regulator cover (51), and in the regulator body (39) through the air delivery tube located in the oral nasal (9). Rinse the hood (2) both inside and out.



Fig. 5.5 The mask should be rinsed thoroughly with fresh water at the end of each diving day.

Wipe the inside of the Band Mask out with a clean, damp rag. Do not depress the purge button while rinsing the regulator as this action will permit foreign matter back into the inlet valve (59) and seat.

5) Screw the demand regulator adjustment knob (47) all the way out. This will prolong the life of the inlet valve seat (59) and keep the internal adjustment correct.

6) Lubricate the shaft of the nose block device (3) with silicone grease. Push and pull the device so the lubricant covers the entire shaft. Wipe any excess from the shaft with a clean cloth.



Fig. 5.6 Lubricate the shaft of the nose block device.

7) When replacing the hood (2) after it is dry, make sure that the hood is properly captured by the mask bands (16, 68). Generally speaking, a used hood will take a “set” and show the signs of compression from the bands (16, 68). This set will correspond to the depression in the mask frame (17) where the bands (16, 68) compress the hood.

When properly installed, the front edge of the hood must protrude a minimum of 1/4 to 1/2 inch (6.0-12.0 mm) all the way around the mask from beneath the bands. The screws (15) holding the bands should be tightened to 26 inch pounds (28 kg cm) of torque. As hoods age and the cells of the neoprene break down it will be possible to tighten the bands to the point where the bands almost touch.

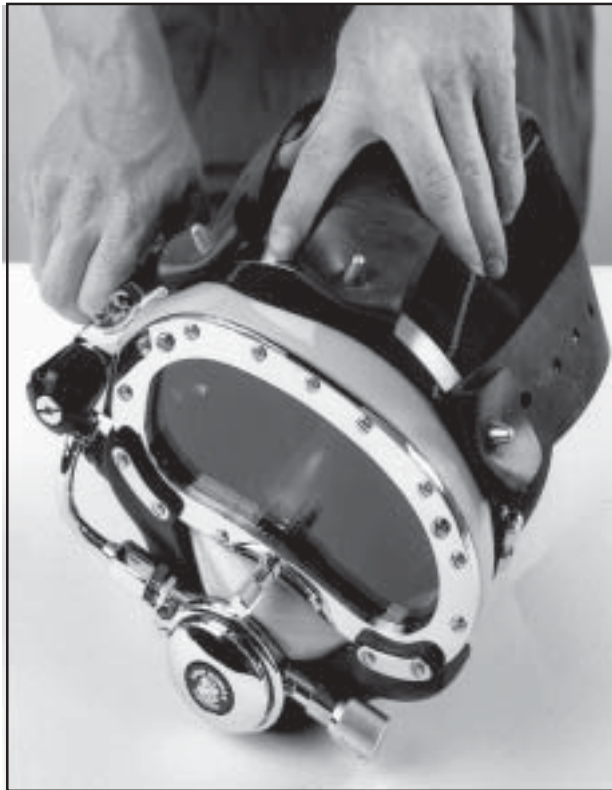

Fig. 5.7 The hood should protrude a minimum from 1/4 to 1/2 inch from under the bands.

The easiest way to install the hood (2) is to slide it on the mask frame (17) and position the bands (16, 68). Start tightening the screws (15) that join the bands slowly turning each a few turns and then the other, bringing the bands together uniformly. Pull the edge of the hood out from under the bands until it protrudes at least 1/4 to 1/2 inch (6.0-12.0 mm). Tighten the bands a bit more and check the hood again. Repeat this procedure until the screws (15) are tightened to 26 inch pounds (28 kg cm) of torque. Test the installation by pulling on the hood and trying to separate it from the mask.

⚠ WARNING: Always ensure that the bands that hold the hood in position are properly tightened prior to diving. If the bands are not tight or the hood is not properly captured the mask could leak or could separate from the hood. This could lead to drowning.

If a new hood is being installed, retighten the band screws (15) after 24 hours to adjust for compression of the rubber.

5.5 MONTHLY MAINTENANCE (OR BETWEEN JOBS)

5.5.1 Communications Inspection (13)

1) Visually inspect the earphones (10,11), microphone (12), wires, lugs, and communications posts (73). Test each component for proper operation. Connect to the deck amplifier and talk back and forth. Replace any weak earphone or microphone.

The microphone (12) is of a special design for underwater use. It has a felt backing that will absorb salt water to help protect the microphone. The microphone should be removed for periodic cleaning. If salt has accumulated on the felt it should be dipped in fresh water to remove the salt.

2) Open the earphone rubber covers and remove the protectors. Allow to dry thoroughly. Replace defective earphones. See Section 6.9.3.

5.5.2 Lubricate Nose Block O-Rings (32)

Tools Required:

7/16 inch Open End wrench

1) Unscrew the nose block device packing nut (33) and lubricate the two O-rings (32) and main shaft (3). Retighten the nut just to the point where the nose block device (3) will still slide, but it requires a firm push or pull.

2) Test the shaft (3) to ensure that it will still slide freely at this time. If it does not, loosen or tighten the nut (33) just enough to permit the shaft (3) to slide properly. A bent nose block device shaft will prevent proper function and could cut the o-ring causing a leak.

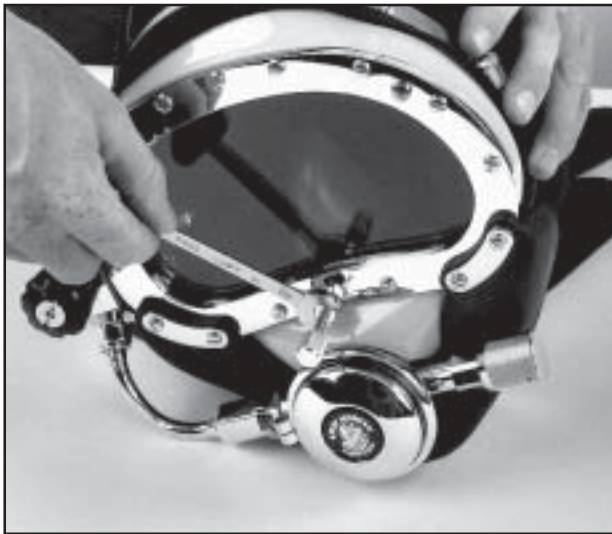

Fig. 5.8 Unscrew the nose block packing nut.

5.5.3 One-Way Valve (103)

5.5.3.1 Disassembly of the One-Way Valve

Tools Required:

Soft Jaw Vice

1 inch Open End Wrench Attachment on Torque Wrench

(If no vise is available use a backup 1 inch open end wrench)

Disassemble and inspect the one-way valve assembly (114)

1) The one-way valve assembly (114) should be removed from the side block (94a/b).



Fig. 5.9 Remove the one-way valve from the sideblock.

2) After the one-way valve has been removed, use two wrenches or hold the hex part of the body (112) in a vise while removing the seat (106) with a wrench.

! CAUTION: Do not use pliers on the main body of the one-way valve. You may damage the valve if pliers are used.

As the seat (106) is removed, the wiper (107) and the O-ring (108) slide out in place in a groove on the seat (106). The poppet (110) and the poppet O-ring (109) usually come out in the seat (106) being followed by the spring (111). The only functional part remaining in the valve body (112) is a non-moving, pressed-in cage. The function of the cage is to prevent the poppet O-ring (109) from blowing out of place during high flows.



Fig. 5.10 If no vise is available you may use two wrenches to disassemble the valve.

3) Inspect the body (112) interior for foreign matter of any type and clean, if necessary.

4) Inspect the seat (106), wiper (107), O-ring (108), poppet O-ring (109) and poppet (110) for wear, replace if necessary. Be sure each part is clean. A repair kit is available for replacement parts. (KMDSI Part #525-330).

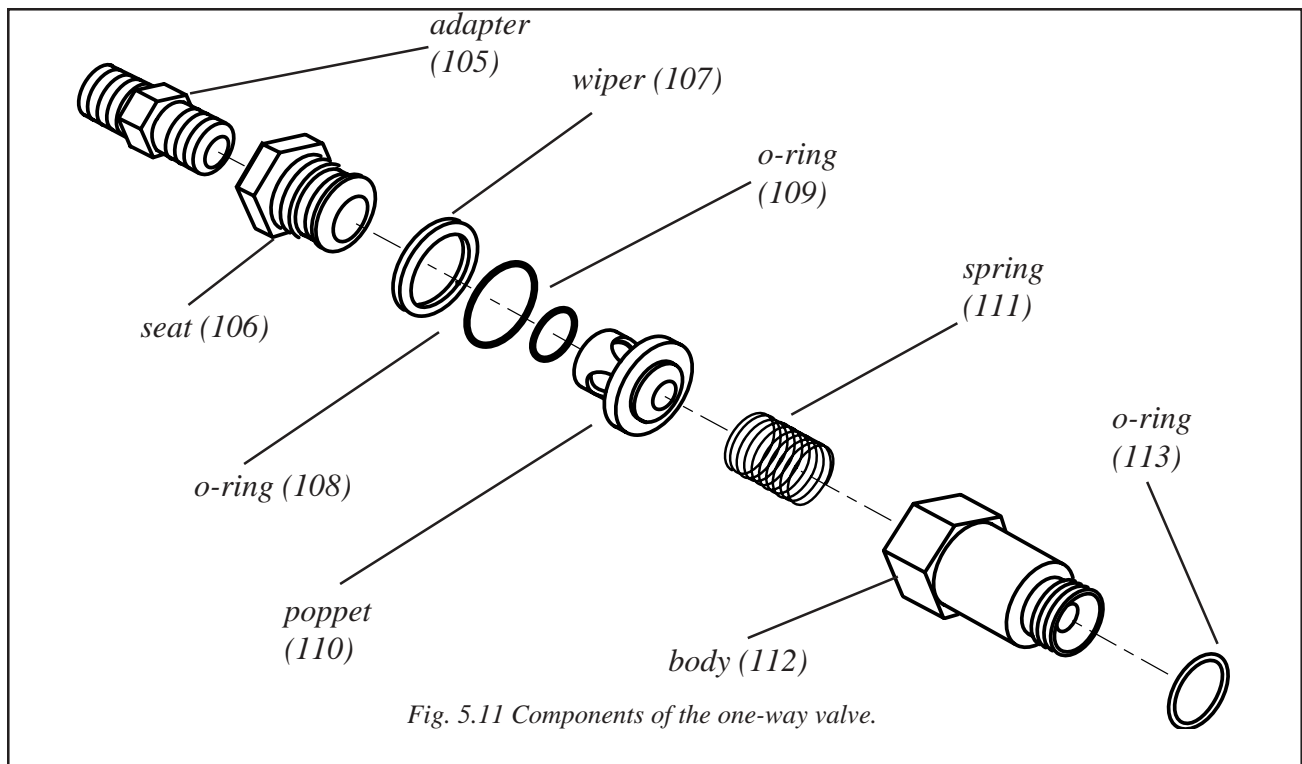

5) Place silicone lubricant on the components then wipe clean. Be careful to wipe the poppet (110) and poppet O-ring (109) thoroughly, removing nearly all silicone to prevent foreign materials from sticking to these components.

6) Inspect the spring (111) and clean or replace if necessary.



5.12 Reassembly of the one-way valve.

5.5.3.2 Reassembly of the One-way Valve (103)

1) Insert the spring (111) in the valve body (112), followed by the poppet (110).

2) The O-ring (109) should engage the poppet (110).

3) Next, install the O-ring (108), wiper (107), on the seat (106).

4) Tighten the seat (106) with a wrench while holding the body in a soft jaw vice.

5) If the adapter (105) has been removed, it should be wrapped with Teflon tape on the tapered pipe threads and reinstalled at this time. Tighten the adapter.

Document #040427004 © Copyright 1970-2004 Kirby Morgan Dive Systems, Inc. All rights reserved.

⚠ DANGER: Do not allow any excess Teflon tape to cover the end of the adapter (105), or to enter the one-way valve (104). Loose pieces of Teflon tape can interfere with the performance of the one-way valve or the regulator and may block the diver's air supply. This could lead to death through suffocation.

7) Reinstall the valve assembly (114) in the sideblock (94a/b) and tighten.

KMB 18 & 28 MANUAL

5.5.4 Demand Regulator (63A/B)

5.5.4.1 Demand Regulator Test for Correct Adjustment, Fully Assembled

Check the regulator for adjustment and proper function with the assembly complete and the breathing gas supply adjusted between 120-150 psig.

1) Press the purge button (51d) in the cover (51b) to check flow. There should be between 1/16 inch and 1/8 inch (1.5-3.0 mm) free travel in the button, then the gas should start flowing. When the button is fully depressed, a strong surge of gas should result.

2) Run the adjustment knob (47) out until a steady flow of gas is present.

3) Run the adjustment knob (47) in until the free flow just stops. Depress the purge button several times to ensure that the regulator has stabilized. If the flow does not stop, check the supply pressure. If it is correct, the regulator will require internal adjustment. See Section 5.6

4) Don the mask and test breathe the mask to check for resistance. If the adjustment knob (47) has been set in accordance with Step #2 above and the regulator breathes hard, internal adjustment is necessary. See Section 5.6

5) Drain the diver's umbilical but be sure the air supply is on to the manifold. Check the exhaust valves (62,66) by turning the defogger control knob (85) and the auxiliary control knob (100) off. Don the Band Mask with the zipper on the hood (2) open. Do not fasten the head harness (1) (spider). Try to inhale. If any leakage is present it could be from the regulator exhaust, or other component leakage.

! DANGER: Do not perform this test unless the diver is stationed immediately adjacent to the diver's air manifold and you are certain the air is on to the manifold. If the diver is unable to breathe air to the Band Mask, either from the umbilical or the bail-out it could lead to panic. A tender should be standing by during this test to assist the diver if required.

Start by visually checking the regulator exhaust valves (62) and the main exhaust (66) for correct seating. If the leak cannot be located in the other components, and the regulator is still suspect, it can be removed, (see Section 6.14.2). Attempt to inhale directly from the mount tube to check the regulator for leaks. A finger should be held over the inlet nipple (61a/b) during this check.

6) When no supply pressure is going to be on the Band Mask for several hours or more, the regulator control knob (47) should be backed all the way out. This will prolong the life of the inlet valve (59).



Fig. 5.13 Back the regulator adjustment knob all the way out when the mask will not be used for more than a few hours.

5.5.4.2 Inspection of Regulator Body Interior (39)

Tools Required:

1/4 inch Flat Blade Attachment on Torque Screwdriver

1) Remove the demand regulator clamp (50) by removing the clamp screw (49).



Fig. 5.14 Remove the regulator clamp screw.

2) Lift off the demand regulator cover (51b) and diaphragm (52).

3) Clean the diaphragm (52) and check it for holes.

4) Inspect the interior of the demand regulator body (39) for foreign objects and cleanliness.

5) Clean if necessary. Make sure the diaphragm (52) has no signs of wear or aging. Do not reassemble yet. Use only replacement diaphragms supplied from Kirby Morgan as others may not stay securely in place.

7) Reinstall the diaphragm (52), cover (51b), and clamp (50). Tighten the clamp screw (49).



Fig. 5.15 Inspect the diaphragm.

5.5.5.1 Adjustment System Lubrication

Tools Required:

3/4 inch Open End Wrench Attachment on Torque wrench

3/32 inch Punch

Small Block of Wood

Ballpeen Hammer

Go to the adjustment knob (47) end of the regulator (63a/b):

1) Unscrew the knob (47) until it stops and a wrench can be placed on the nut (46).

2) Remove the nut (46). The adjustment shaft (43) and the knob (47) are removed with the nut (46).

3) Punch out the retaining pin (48) with a 3/32" punch. While driving the pin through, support the adjustment end with a block of wood to avoid bending the shaft (43). Be careful or damage may result to the adjustment shaft (43).

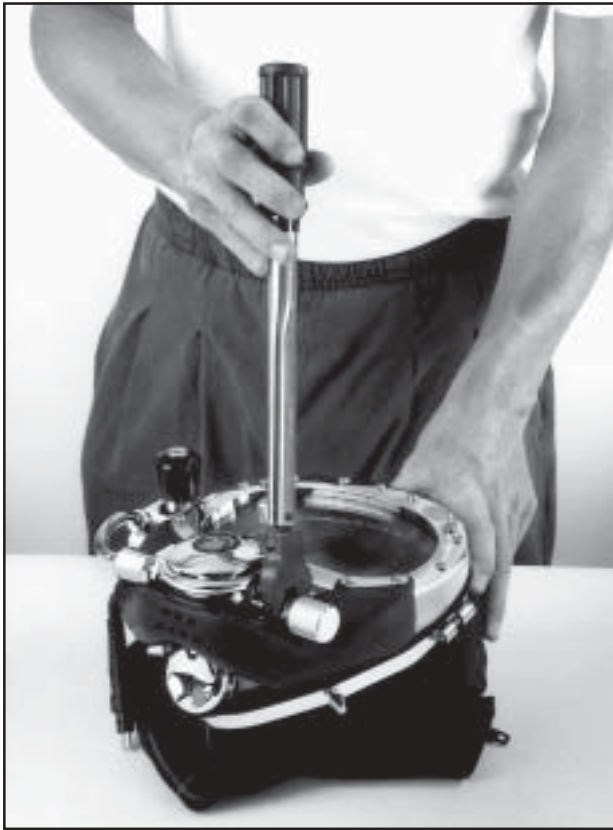

Fig. 5.16 Unscrew the packing nut to remove the adjustment knob.



Fig. 5.17 The adjustment end of the regulator.

4) Remove the washer (44) and O-ring (45).

5) Turn the Band Mask on its side (side block (120a/b) at the top) and shake out the spacer (42), spring set (41), and piston (40).

6) Clean and lubricate generously with silicone grease.

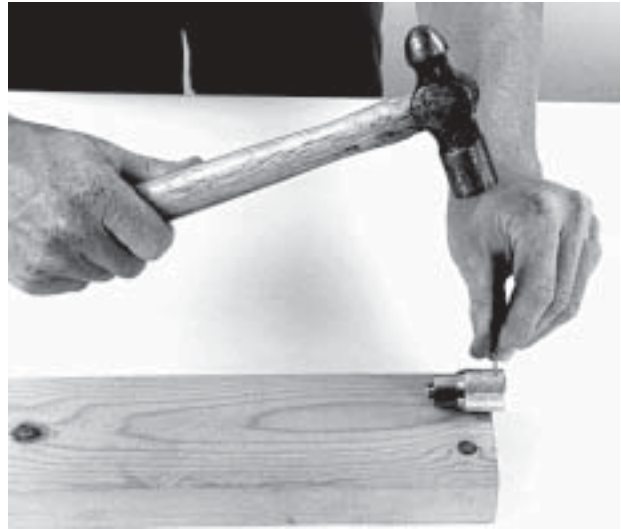

Fig. 5.18 Removing the pin from the adjustment knob.

7) Inspect the O-ring (45) for cuts. Replace if necessary.

8) Inspect the washer (44) for wear. Replace if necessary.

9) Inspect the inside of the adjustment tube to be sure there is no corrosion and the adjustment assembly can travel freely.

5.5.5.2 Reassembly of Adjustment System

1) Place the piston (40) back in the regulator adjustment tube, followed by the spring set (41), and spacer (42). The narrow end on the spacer fits into the spring set.



Fig. 5.19 Install the piston in the regulator.

2) Place the washer (44) and O-ring (45) on the shaft (43).



Fig. 5.20 Replace the washer and O-ring if necessary.

3) Slip the packing nut (46) over the shaft (43) followed by the adjustment knob (47).

4) Drive the pin (48) back into place until it is flush with the surface of the adjustment knob (47).

5) Screw the shaft (43) back into the regulator body (39) until it just stops.

6) Thread the packing nut (46) onto the regulator body (39) and tighten with a 3/4 inch torque wrench.

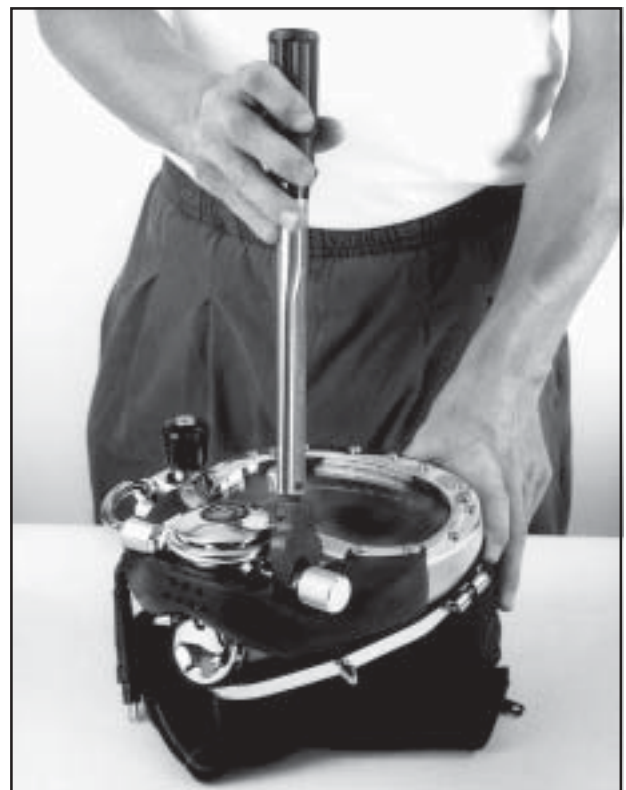

Fig. 5.21 Tighten the packing nut with the torque wrench.

KMB 18 & 28 MANUAL

5.6 DEMAND REGULATOR INTERNAL ADJUSTMENT WITH OR WITHOUT SPECIAL TOOLS

Tools Required:

Small flat blade screwdriver

Needle nose pliers

KMDSI Regulator Tool Kit, Part # 525-620

1. Remove the regulator clamp (50), leaving the cover (51b) and diaphragm (52) on the regulator.

2) Adjust the regulator adjustment knob all the way in. Finger tight only.

3) Pressurize the regulator to between 120-150 psig (8.5-10 bar).

4) Holding the cover (51b) in place, slowly back out on the adjustment knob until a slight free flow is heard and then rotate the adjustment knob in (clockwise) 1/4 turn and depress the purge button momentarily. Repeat this procedure until the regulator gas flow stops. Usually the regulator adjustment knob will end up between 5 and 7 turns out when the free flow stops. **Note: If when backing the adjustment knob out from the full “in” position, the regulator starts free flowing at less than five turns, this usually indicates there is not enough free play in the lever.**

5) Upon completion of step 4. The demand lever (55) should have between 1/16 - 1/8 inch (1.5 - 3.0mm) play. If adjustment is necessary, adjust using the KMDSI regulator adjustment tools if available or use the alternative method.



Fig. 5.22 Checking the play in the lever.

6) **KMDSI tools:** Using the inlet valveholding rod, (L shaped rod), insert the end of the rod into into the balance hole as shown in Fig 5.23. Lightly apply force by pushing on the rod making it act as a lever to put friction against the inlet valve shaft. At this point, the KMDSI wrench can be used to rotate the lever nut (53). Rotate the nut “In” (clockwise) to reduce lever play or “Out” (counterclockwise) to increase lever play. Only rotate the nut 1/8 turn at a time as this is a very sensitive adjustment. Remove the tools and depress the lever several times after adjusting to ensure the correct play is achieved. It may be necessary to repeat this procedure several times, as the method requires estimating the correct position of the nut. **(Note: If there is little (less than 1/16 inch 1.5mm) or no lever play, the regulator will free flow. If there is too much free play, (more than 1/8 inch (3.0mm) the regulator will not be capable of full demand flow potential.**



Fig. 5.23 Using the KMDSI Regulator Adjustment tools.

Alternative method: If a KMDSI tool kit is not available, a small jewelers screwdriver or metal scribe can be inserted in the slot on the end of the inlet valve (59) to keep it from rotating, and then needle nose pliers may be used to rotate the lever nut (53). Adjust as described in step 5.

7. When adjustment is complete, place the diaphragm (52) and cover (51) in place, and press tightly down on the cover to simulate the action of the clamp.



Fig. 5.24 Push down tightly on the cover.



Fig. 5.25 Pressing the purge button.

8) Depress the purge button (52d) in the center of the cover (51b).

9) There should be 1/8 inch (3.0 mm) of free travel before the button comes in contact with the diaphragm.

10) The lever (55) must now be adjusted to the correct height if it is not already correct. The nut (53) can be loosened no more than 1/8 of a turn to lower the lever height. The lever must be bent if more adjustment is necessary.

Note: Before bending the lever, double check the adjustments. It is very rare that the lever ever has to be bent in a regulator that has been in service. Usually levers only require bending in new installations or because of damage during disassembly.

! CAUTION: Be careful not to place undue stress on the lower arms of the lever (55) as this will disfigure the lower blades and cause spongy operation.

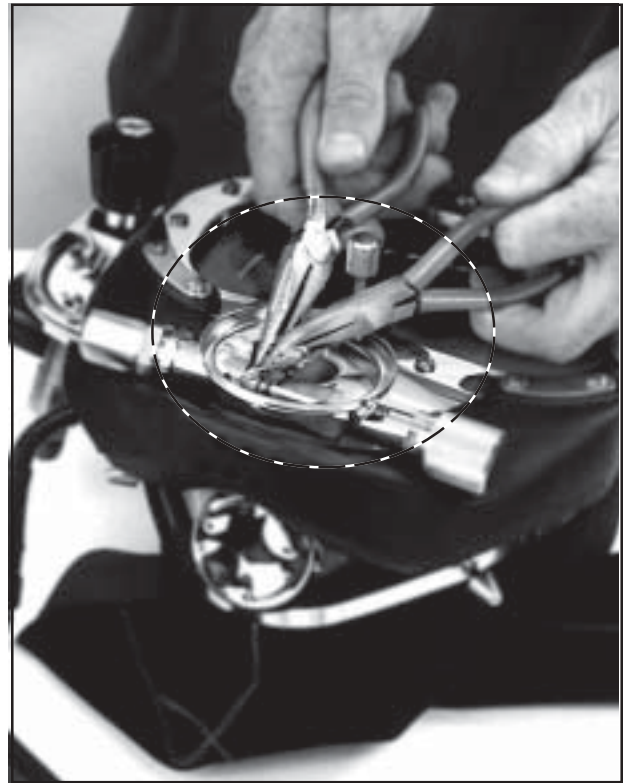

Fig. 5.26 Bending the lever up.

11) To bend the lever down, place the disk end of the KMDSI 1/4 inch wrench onto the flat area of the adjustment tube inside the regulator. Next slide the disk, as far as possible under the new lever (55). With your finger bend the lever down over the disk to the desired height. **Be careful not to bend the lever too far!**



Fig. 5.27 Use the round end of the adjustment wrench for leverage in bending the lever down.

12) Replace the diaphragm (52) and cover (51). Continue until the proper tolerances are reached.

13) If a new inlet valve (59) has been installed, allow the regulator to sit for 24 hours with the adjustment knob (47) turned all the way in, before adjusting. This will allow the rubber in the inlet valve stem to take a set against the inlet nipple (61a/b). If the regulator is to be used immediately, be aware that the rubber seat will take a set, changing the adjustment and the regulator's performance. This requires the readjustment of the regulator after the first diving day following the proper setting time and procedure.

14) The two opposing blades of the lever (55) must be in perfect alignment with each other and be free of nicks or burrs.

15) If the regulator continues to free flow after the adjustments are made, the regulator should be completely disassembled, inspected. It usually will require a careful inspection of the inlet valve seat surface and the inlet valve. See 6.14.3.

5.7 Hood and Band Keeper Removal and Replacement

Tools Needed:

- Flat Blade Screwdriver
- Torque Screwdriver w/Flat Blade & Philips Attachments
- #2 Philips Screwdriver
- Large Philips Screwdriver
- RTV Silicone Sealant (Dow Corning #732)

5.7.1 Hood, Bands and Band Keeper Attachment Plates Removal

1. Remove the Top and Bottom Band Keeper Attachment Plates (121, 123b) by removing the Screws (122, 123c) that are mounting them.
2. Loosen the Band Adjustment Screws (15) and take the Hood (2) off of the Mask Frame (17).
3. Remove the Earphones (10, 11) from the pockets in the Hood (2) and remove the Hood (2).
4. Remove the Band Adjustment Screws (15) from the Bands (16, 68) and remove the Bands (16, 68) from the Hood (2).

5.7.2 Band Keeper Mounts Removal and Replacement

1. To remove the Top Band Keeper Mount (123c), remove the three mounting Screws (124).
2. To install the Top Band Keeper Mount (123c) screw it onto the front of the Port Retainer (28) with Screws (124). Use a torque Screwdriver and tighten the screws to **12 Inch Pounds**.

3. To remove the Bottom Band Keeper Mount (121a), remove the Comfort Insert (14)(KMB-18's Only) and mounting Screws (6)(KMB-18's Only), then removing the Screws (125) and carefully prying the Mount (121a), that is sealed to the Mask Frame (17) using Silicone, from the Mask Frame (17).

4. To install the Bottom Band Keeper Mount (121a), clean the old Silicone from the Bottom Band Keeper Mount (121a) and the Mask Frame (17). Apply a adequate amount of Silicone Sealant on the back side of the Mount (121a) and secure it to the outside of the Mask Frame (17) using Screws (125). Wipe off any excess Silicone.

Inspect / Replace

Inspect the Hood, Bands, Adjustment Screws, Band Keepers and all related parts for damage and/or wear and replace if necessary.

5.7.3 Hood, Bands and Band Keeper Attachment Plates Installation

1. Reinstall the Comfort Insert (KMB-18's only).



Fig. 5.28 Feed the Bands into the hood

2. Feed the Bands (16, 68) into the Hood (2) through one of the large holes on the sides.

3. Start the Band Adjustment Screws (15) onto the Bands (16, 68) only 2 - 3 turns.

4. Place the Mask Frame (17) face down on a work surface and install the Earphones (10, 11) into the Earphone Pockets in the Hood (2).



5. Slip the Hood (2) and Bands (16, 68) onto the Mask Frame (17) until they are both correctly positioned and centered.

Note: On KMB-28's it may be necessary to place the Adjustment Block part of the Band (68) between the Side Block (94b) and the Mask Frame (17) first before sliding on the other side of the Hood (2) onto the Mask Frame (17).

6. Using a Large Philips Screwdriver lightly snug the Band Adjustment Screws (15) onto the Mask Frame (17) for the moment. Tighten the Band Adjustment Screws (15) equally on each side checking the position of the Hood (2) and Bands (16, 68) as you tighten.

7. Place the Top Band Keeper Attachment Plate (123b) over the top, center Head Harness Mount Stud on the Band (16) and attach it to the Mount (123a) using Screw (123c) and tighten.



8. Place the Bottom Band Keeper Attachment Plate (121) over the lower port side Head Harness Mount Stud on the Band (68) and attach it to the Mount (121a) using Screw (122) and tighten.



9. Use a Torque Screwdriver and tighten the Band Adjustment Screws (15) to 26 Inch Pounds.

CHAPTER 6

CORRECTIVE MAINTENANCE

6.1 GENERAL

This section covers the maintenance and repair of the Kirby Morgan Band Mask 18A/B and 28. Correct repairs will result in better communications, easy breathing, and improved overall diver performance in getting the job done. Numbers appearing in parentheses below are “location” numbers that are used in the blow-apart drawing at the rear of this manual.

! DANGER: Use only Kirby Morgan Dive Systems, Inc. original replacement spares when repairing your Band Mask. The use of other manufacturer’s parts will interfere with the performance characteristics of your life support equipment and may jeopardize your safety. Additionally, any substitutions will void all warranties offered by KMDSI.

All the spare parts in our catalog were specifically manufactured for Kirby Morgan designed helmets and masks. When ordering spares, insist on KMDSI original parts.

! DANGER: All parts on the Kirby Morgan Band Mask 18A/B and 28 must be adjusted to their proper torque specifications. See Appendix 1 for a complete listing of torque specifications for each part. Failure to adjust parts to the recommended specifications could lead to Band Mask failure and accidents. This could be fatal.

6.2 PORT RETAINER (28)

The port retainer (28) is made of chrome plated brass. Under normal use, the port retainer (28) should never need replacement.

6.3 FACE PORT (27)

6.3.1 General

The face port (27), or viewing lens, is made of a polycarbonate plastic. Small scratches on the exterior are not important as they tend to disappear underwater. However, the face port is easily replaced by removing the port retainer (28) and dropping in a new face port.

Note that there are two different face ports, one for the KMB 18 and one for KMB 28. *They are not interchangeable.* The face port for the KMB 18 is Part #520-004. The face port for the KMB 28 is Part #520-128.

! DANGER: The face ports for the KMB 18A/B and KMB 28 are not interchangeable. Do not attempt to use a face port from a KMB 28 in a KMB 18A/B. Although the port will fit into the mask frame, it will not seal properly. This will lead to continuous leakage of the mask and could cause a rapid depletion of the diver’s breathing gas as he attempts to clear the mask.



Fig. 6.1 The face port from the KMB 28 will not fit properly in a KMB 18A/B. NOTE THE GAP WHERE THE PORT DOES NOT PROPERLY FILL THE SPACE.

⚠ DANGER: Never use a third party face port. Its thickness or diameter may be incorrect and cause it to flood. It could also be made of inferior materials causing it to fail. This could be fatal.

6.3.2 Face Port (27) and Nose Block Device (3) Removal

Tools Required:

7/16 inch Open End Wrench

1/4 inch Flat Blade Attachment on Torque Screwdriver

Slip Joint Pliers

1) First remove the nose block device knob (34) then the packing nut (33).



Fig. 6.2 Remove the nose block device knob.



Fig. 6.3 Remove the nose block packing nut.

2) Slip the O-rings (32) off the nose block shaft (3) and pull the nose block device out through the interior of the oral nasal mask.

3) Next, unscrew the port retainer screws (29, 38). Pull the retainer (28) clear of the Band Mask frame (17).

4) Be sure not to lose the O-ring (31) that is located on the back side of the port retainer (28) at the nose block device packing.

5) The four whisker spacers (36) must not be misplaced. They will usually be found lodged in the whisker (35).

6) Remove the old port (27) and sealing O-ring (26).



Fig. 6.4 Removing the port retainer screws.

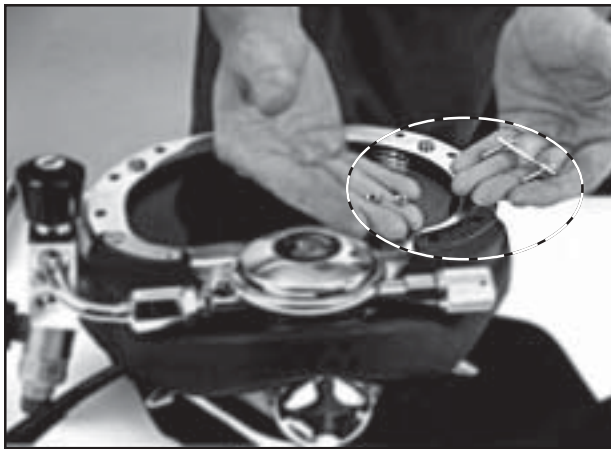

Fig. 6.5 Don't lose the whisker spacers.

6.3.3 Face Port (27) and Nose Block Device (3) Replacement

1) Clean the O-ring groove that is in the Band Mask frame (17).



Fig. 6.6 Clean the O-ring groove.

2) Lightly coat the port O-ring (26) with silicone lubricant and replace in the Band Mask frame (17).

! WARNING: The O-ring in the face port of the Kirby Morgan Band Mask 18A/B and 28 is made from a special compound and has unique dimensions. It is a softer durometer O-ring than is commonly available. There are no equivalent O-rings manufactured by other vendors. This O-ring must be replaced with a KMDSI O-ring. Failure to do so could lead to seal failure.



Fig. 6.7 Install the port O-ring .

3) Place the new face port (27) into the Band Mask frame (17) making sure the O-ring (26) is in its proper place.

4) Clean and lubricate the O-ring (31) located on the back side of the port retainer (28).

5) Slip the O-ring (31) on the small tube that protrudes from the rear of the port retainer (28). Place the entire port retainer (28) onto the Band Mask frame (17), holding it in place against the port (27) and O-ring (26) while the screws (29, 38) are all run in loose.

6) Slightly tighten each screw (29,38), one after another, until they are all snug (12 inch pounds (13 kg cm) of torque) and the O-ring (26) has completely sealed the face port (27).

! DANGER: Always use a torque screwdriver to check the tension of the port retainer screws. Overtightening can damage the threaded inserts in the fiberglass or plastic frame and cause them to loosen. Without the correct tension the port retainer may come loose and the Band Mask could flood. This could lead to drowning. If the inserts do become loose, the mask must be returned to KMDSI for repair.

! WARNING: Damage to the inserts on a KMB 28 cannot be repaired and requires the replacement of the mask frame.



Fig. 6.8 Be sure to install the small O-ring that seals the nose block device on the back side of the port retainer.

7) Install the nose block device (3) from the interior of the oral nasal mask (9) and out through the lower packing fitting on the port retainer (28).

8) Slide the two lubricated O-rings (32) onto the shaft of the nose block device (3).

9) The packing nut (33) is threaded into place followed by the nose block device knob (34).

10) Tighten the packing nut (33) until some resistance is felt when the nose block device knob (34) is pushed in and out. Tighten the nut (33) until the shaft will no longer slide, then back the nut off until the shaft begins to slide again.

11) If this nut is too tight the nose block device (3) cannot slide in and out.

! WARNING: The material used in the face port (27) is very strong. However, certain chemicals will attack the polycarbonate and weaken it. Some solvents used for grease removal will attack the polycarbonate. Use only mild detergents or organic soaps to clean the face port. Never allow overspray of silicone lubricant to get on the face port. Although the silicone lubricant is non-injurious, the propellant is usually Freon (chlorinated hydrocarbon) that will damage the port. This could cause the face port to fail after a minor impact.



Fig. 6.9 The port retainer screws must be accurately tightened with a torque screwdriver.

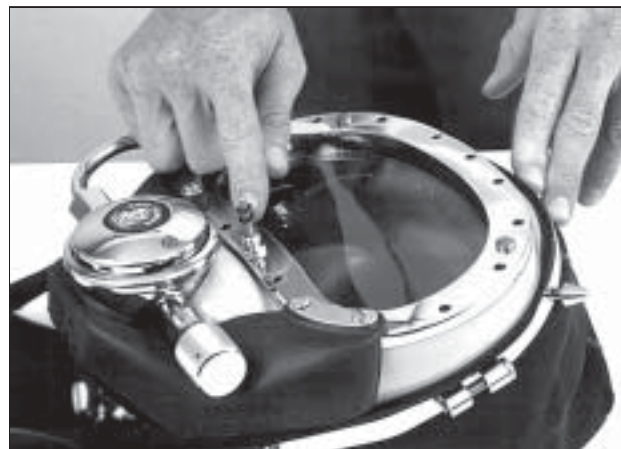

Fig. 6.10 Install the two O-rings on the nose block shaft.

12) The nose block device knob (34) should be tightened with a pair of pliers padded with a rag so as not to damage the knurl & plating.

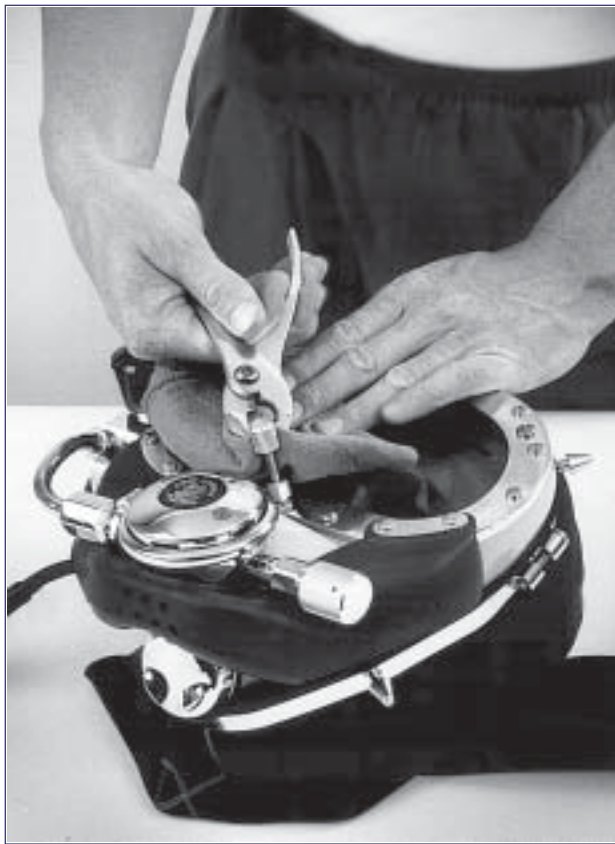

Fig. 6.11 Use a pair of pliers and a rag to tighten the nose block device knob.

6.4 COMMUNICATIONS SYSTEM

6.4.1 General

The communications system in the Kirby Morgan Band Mask 18A/B and 28 requires regular attention and maintenance for proper function. Clear two way speech communications between the diver and his surface crew is one of the most important capabilities of surface supplied diving operations.

Communications may be either two wire or four wire. See Section 6.4.5 on four wire systems.

6.4.2 Earphone Inspection

To service the earphones, remove the hood (2) from the Band Mask first (see Section 5.4 for hood removal and replacement). The earphones (10, 11) can be carefully pulled out of the hood (2) for inspection and disassembly.

1) The rubber front cover is removed first, the rear cover is next removed. The protector is now free.

2) Check the wire connections. They must be solid.



Fig. 6.12 Removing the rubber cover from the earphone.

3) Check the Mylar diaphragm. If the mylar is torn, or loose, replace the entire unit. Although cardboard speakers are available at a lower initial cost than our mylar speakers, they are a poor investment. Cardboard speakers must be replaced almost five times as often as our mylar speakers. Cardboard speakers should only be used when genuine Kirby Morgan speakers cannot be obtained.

4) If the rubber covers are not good, replace them also.



Fig. 6.13 Inspect the mylar cones.

6.4.3 Microphone (12) Removal and Replacement

Tools Required:

1/8 inch Flat Blade Screwdriver

The entire microphone (12) is replaced the same as the earphones by removing the wire lugs from the communications posts (73) or terminal block (82) and replacing the entire unit.

1) Remove the nuts (71) and washers (72) from the communications posts (73). If you are using the optional terminal block (82) this may be where the wires from the earphone and microphone are connected.



Fig. 6.14 Remove the nut from the communications posts.

2) Lift the terminal lugs off of the communications posts (73). Note the position of the terminal wires.

3) Slowly pull the microphone (12) out of the oral nasal mask (9). The wires that connect it to the communications posts (73) will follow.



Fig. 6.15 Remove the microphone from the oral nasal mask.

4) The microphone (12) is of a special design for underwater use. It has a felt backing that will absorb salt water to help protect the microphone. The microphone should be removed for periodic cleaning. If salt has accumulated on the felt, it (just the felt) should be dipped in warm fresh water to remove the salt.

5) If you are installing a new microphone (12) or reusing the old one it must be seated in the oral nasal mask (9). Install the terminal lugs for the new microphone (12). Note that the wires must go on separate terminals as before.

6) Tighten the nuts (71) carefully, without turning the communications posts (73). If the posts turn, it means that the seal made by the silicone sealant (RTV) on the mask frame has been broken. If this happens the posts (73) will allow water to leak into the mask. (See Section 6.4.6.2 for repair)



CAUTION: Take care not to break the seal made by the silicone sealant where the communications posts penetrate the mask frame. If these posts turn the mask will leak. This could lead to a rapid use of the breathing gas as the diver attempts to keep the mask clear.

6.4.4 Earphone (10,11) Removal and Replacement

Tools Required:

1/8 inch flat Blade Screwdriver

The earphones (10,11) may be replaced individually if needed, however, if one is “bad”, the other earphone will probably need to be replaced soon, too.

1) Remove the nuts (71) and washers (72) from the communications posts (73). If you are using the optional terminal block (82) this may be where the wires from the earphone and microphone are connected.

2) Note the position of the terminal wires. Lift the terminal lugs off of the communications posts. Discard the old earphones.

4) Install the terminals for the new earphones (10, 11). Note that the wires must go on separate terminals as before.

5) Tighten the nuts (71) carefully, without turning the communications posts (73). If the posts turn, it means that the seal made by the silicone sealant (RTV) on the mask frame has been broken. If this happens the posts (73) will allow water to leak into the mask.

(See Section 6.4.6.2 for repair)

6.4.5 Waterproof Connector (80)

Kirby Morgan Band Masks 18A/B and 28 are supplied either with an optional waterproof connector (80) or a set of communication posts. The optional waterproof connector (80) is subject to failure if the Band Mask receives rough handling. To replace the connector use the following procedure.

6.4.5.1 Waterproof Connector (80) Removal

Tools Required:

3/8 inch Open End Wrench

5/8 inch Open End Wrench

11/16 inch Open End Wrench

3/4 inch Open End Wrench

1) KMB-18 only, remove the comfort insert (14).

2) Remove the connector wire lugs from the interior terminal block (82).

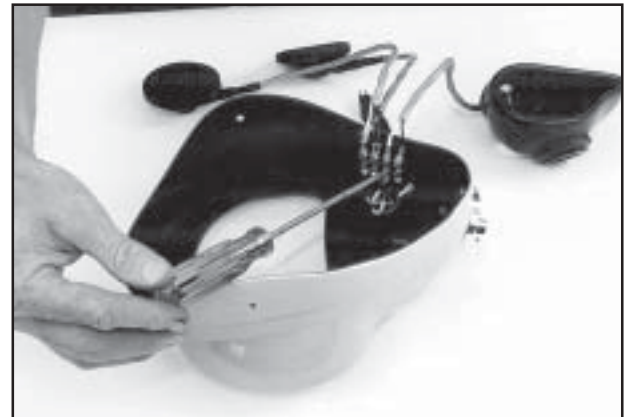

Fig. 6.16 Remove the earphone wire lugs from the terminal block.

3) Remove the nut (70) from the packing gland (76) on the interior of the mask frame (17).

4) Separate the connector/packing gland assembly (76, 74, - 81) from the mask frame (17).

5) Place the packing gland (76) in a vice and unscrew the packing nut (79).

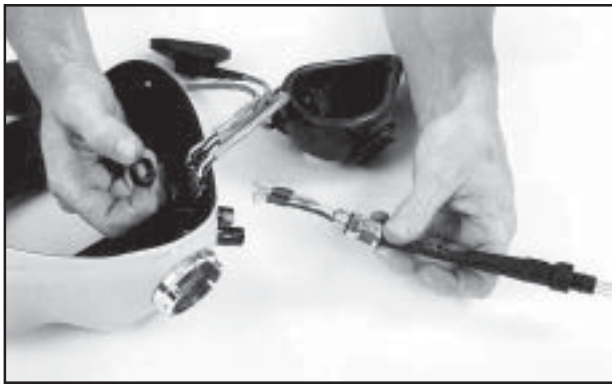

Fig. 6.17 Separate the connector from the mask frame.

6) Pull the connector (80) through the gland (76). (Note: It will be much easier to do this if the lugs (81) are cut off the end of the connector (80) first. Save the front and back ferrules (77, 78) and the packing nut (79).

(Note: The entire waterproof connector assembly (80a) may also be replaced with Part #505-047 Waterproof Connector Assembly.)

6.4.5.2 Connector (81) Replacement

1) Lubricate the new connector (80) with silicone grease.

2) Slide the packing nut (79) and ferrules (77, 78) onto the new connector (80).



Fig. 6.18 Slide the packing nut and ferrules onto the new connector.

3) Feed the connector (80) through the packing gland (76). If the lugs (81) were removed, solder them onto the connector wires.

4) Check the O-ring (74) on the packing gland (76). Replace or lubricate as necessary.

5) Install the connector/packing gland assembly (74, 76-81) in the mask frame (17).

6) Install and tighten the nut (70) on the packing gland (76) until it is snug.

7) Connect the wire lugs (81) on the connector to the communications posts (73) or terminal block (82) if used.



Fig. 6.19 Tighten the nut on the packing gland.

6.4.6 Communications Posts (73)

6.4.6.1 Communications Post Removal

Tools Required;
3/8 inch Open End Wrench

1) Disconnect the communications set (13) as per Sections 6.4.3 and 6.4.4.

2) Remove the nut (71) and washer (72).

3) Pull the communications post (73) away from the mask frame (17).

6.4.6.2 Communications Post (73)

Replacement

- 1) Clean off all the old RTV silicone sealant from the mask frame (17) and communications post (73).
- 2) Apply fresh RTV to the communications post(s) (73).



Fig. 6.20 Apply fresh RTV silicone sealant to the communications posts prior to installation.

- 3) Insert the communications posts (73) into the mask frame (17).
- 4) Install the washer (72) followed by the nuts (71). Tighten the nuts to 15 pounds of torque.
- 5) Wipe off all the excess silicone sealant (RTV) from the mask frame (17).

6.5 SIDE BLOCK ASSEMBLY (119A/B)

6.5.1 GENERAL

The major difference in the Kirby Morgan Band Mask 18A and the Kirby Morgan Band Mask 18B is the side block (94a/b) shape. It is important to also note that the bent tube (117b) and the “A” hose (117a) are *not* interchangeable, nor are the inlet nipple (61a/b) and jam nut (61c). All the other components of the side block assembly (120a/b) are identical and interchangeable between the “A” and “B” models. The mounting arrangement is also identical, allowing the “A” model to become a “B” by changing the side block (94A/B). The configuration of the side block on the KMB 28 is identical to the KMB 18B.

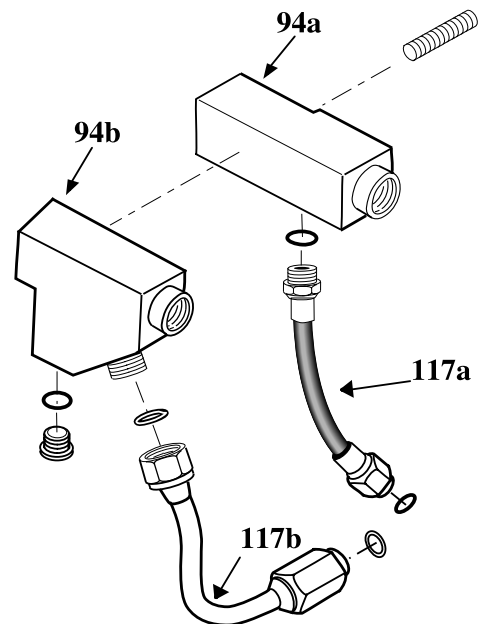

The side block assembly (120a/b) is held in place on the Band Mask frame (17) by a stud (93), flat washer (18), lock washer (19), nut (20), and a machine screw (25). On the “28”, the flat washer (18), is replaced by a standoff (24). The screw (25) does some securing but its main function is to prevent rotation of the side block (94a/b). The stud (93) also extends into the interior of the Band Mask frame (17) far enough to secure the air train (21) by means of the washer (23) and nut (22).

KMB 18 & 28 MANUAL

The air train (21) that fits over the stud (93) is made of soft material. The nut (22) should always be tightened just to 20 inch pounds (23 kg cm) to prevent crushing the air train cup. RTV silicone rubber compound is used to form a gas tight seal between the side block assembly (120a/b) and the Band Mask frame (17).

6.5.2 Sideblock Assembly (120A/B) Removal

6.5.2.1 KMB 18A

Tools Required:

7/16 inch Open End Attachment on Torque Wrench

5/8 inch Open End Attachment on Torque Wrench

13/16 inch Open End Attachment on Torque Wrench

1/4 inch Flat Blade Stubby Screwdriver

On the Kirby Morgan Band Mask 18A, disconnect the hose assembly (119a) at the regulator (63a) end of the hose. Be sure to use a backup wrench on the "A" nipple (61a). The side block assembly (120a) is ready to start removal. (see Section 6.5.2.3)



Fig. 6.21 The hose assembly must be removed prior to removal of the side block.

6.5.2.2 KMB 18B & 28

Tools Required:

11/16 inch Open End Attachment on Torque Wrench

7/8 inch Open End Wrench Attachment on Torque Wrench

7/16 inch Open End Attachment on Torque Wrench

1/4 inch Flat Blade Stubby Screwdriver

On the Kirby Morgan Band Mask 18B and 28, the bent tube assembly (117b) must be entirely removed before removal of the side block assembly (94b) is started.

1) Completely unthread the bent tube assembly (119b) nut from the side block (94b).

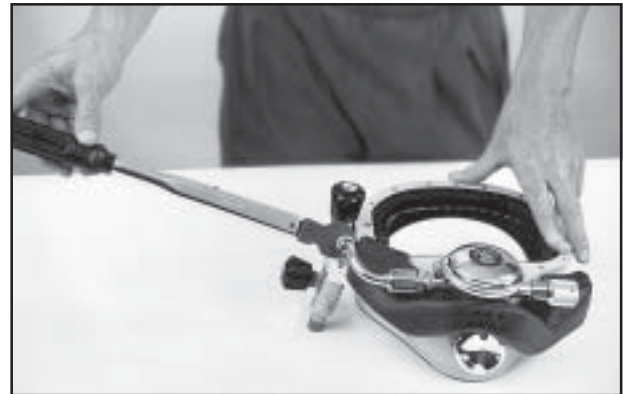

Fig. 6.22 Disconnect the bent tube assembly from the sideblock.

2) Using two wrenches, hold the bent tube mount nut (117b) with the first wrench. With the other wrench, loosen the jam nut (61c) by turning the wrench DOWN. (Fig.6.23)

3) Unthread the mount nut until it comes free, then pull the bent tube assembly (117b) straight out of the regulator inlet nipple (61b).

4) The side block assembly (120b) is ready to start removal.

6.5.2.3 Separating the Sideblock Assembly (120A/B) from the Band Mask Frame (17)

Tools Required:

Putty Knife

7/16 inch Open End Attachment on Torque Wrench

1/4 inch Flat Blade Stubby Screwdriver

1) Remove the nut (22) and washer (23), then the air train (21).



Fig. 6.23 Loosen the jam nut prior to removing the bent tube.

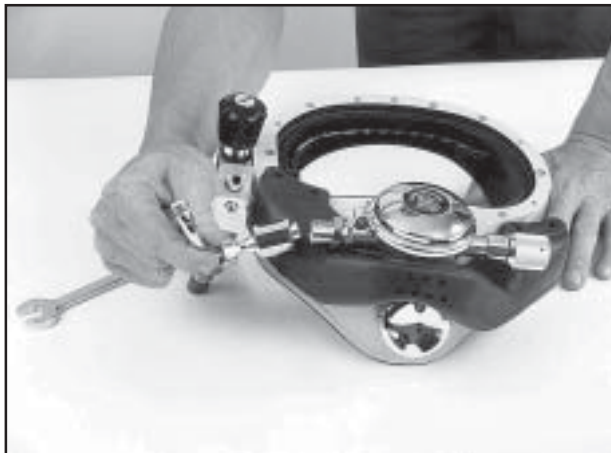

Fig. 6.24 Pull the bent tube assembly straight out of the regulator nipple.



Fig. 6.25 Remove the nut and washer from the air train.

2) The stud nut (20) is removed next, with the lock washer (19) and flat washer (18) on the 18A/B. On the KMB 28 the stud nut (20), the lock washer (19) and the air train standoff (24) would be removed.



Fig. 6.26 Remove the stud nut.



Fig. 6.27 The air train standoff on the KMB 28.

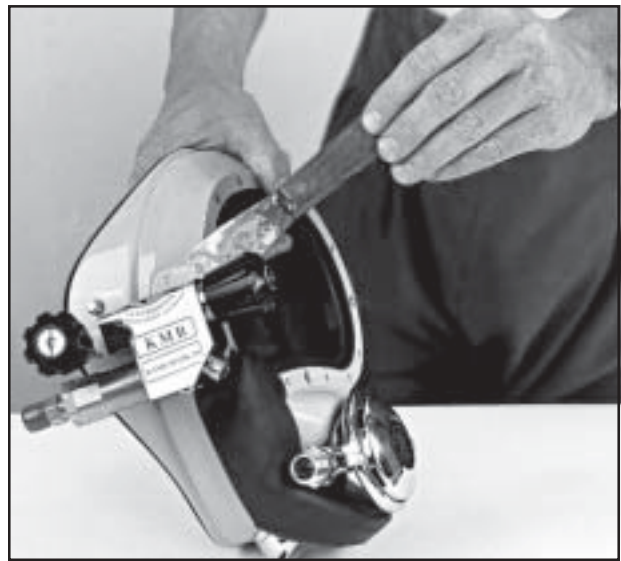

Fig. 6.29 Use a thin putty knife to separate the side block from the mask frame.

3) Next, the screw (25) is removed using the stubby screwdriver.



Fig. 6.28 Remove the alignment screw.

4) The side block assembly (120a/b) is now unfastened, but held in place by RTV (silicone sealant) that acts as a glue. It may be necessary to **slightly** rock or pry the side block from the Band Mask frame (17). A thin putty knife can be pushed between the side block and the Band Mask frame to help free it. The side block assembly (120A/B) must be pulled straight out off of the mask frame (17), not at an angle. The stud (93) has to come through the frame and can cause damage if the side block is forced out at an angle. Be sure to peel or scrape the old silicone sealant (RTV) away from both sealing surfaces before reassembling. Lacquer thinner helps remove this, but carefully since it will also remove the flat black finish inside the KMB 18 Band Mask.

5) If you plan to rebuild the side block (94a/b), it should be done at this time. (See Section 6.6)

6.5.3 Sideblock Assembly (120A/B) Replacement

If a new side block is being installed, make sure it aligns correctly in the holes of the Band Mask frame (17) before applying RTV (silicone sealant).

1) A generous application of silicone sealant (RTV) must be applied to the side block assembly (120a/b) prior to installation on the Band Mask frame (17). Use only Dow Corning® #732 Silicone sealant or equivalent. **Care must be taken to avoid sealant entering the air passageway in the side block.** Be sure to remove all excess silicone sealant (RTV) before it sets up. Lacquer thinner can be used to dissolve unset sealant.

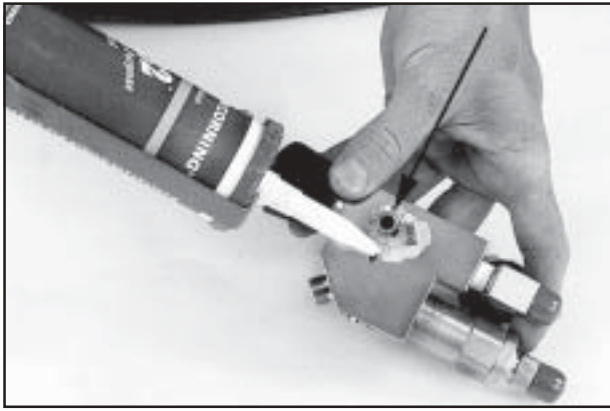

Fig. 6.30 The silicone sealant must not to block the air tube opening.

⚠ WARNING: Do not dive the Band Mask until the sealant has had time to cure. Check the directions on the tube of sealant for curing time. If the Band Mask goes into the water before the sealant has cured it could leak through the side block mounting stud hole, screw hole, or air flow hole. Do not breathe the fumes given off by uncured silicone sealant.

2) Immediately after applying the silicone sealant, push the screw (25) through the Band Mask frame (17) and thread into the side block (94a/b) body.

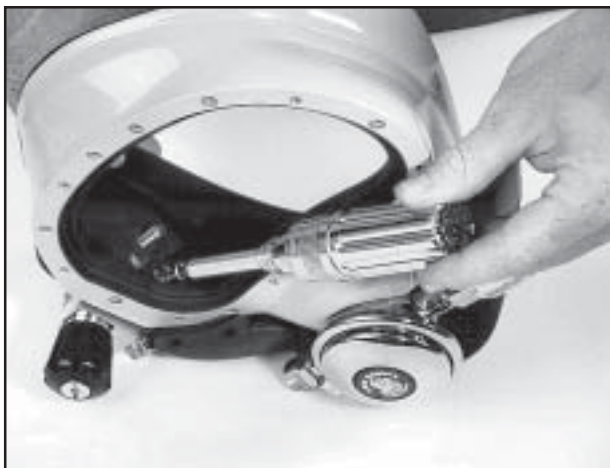

Fig. 6.31 Tighten the screw to the correct torque value.

⚠ DANGER: Do not breathe the fumes from uncured silicone sealant. These fumes are dangerous and can cause unconsciousness. They can also cause long term damage to body tissue.

3) On the KMB 18, slide the flat washer (18) and the lock washer (19) onto the stud (93). Run the stud nut (20) down the stud (93). Torque the nut (20) to its proper setting. If you are using the KMB 28, the air train standoff (24) will be installed on the stud (93) and then the lock washer (19) and the stud nut (20). Torque the nut (20) to its proper setting. Torque the screw (25) to its proper setting. (see Appendix 1 for Torque Specifications.)

4) Slip the air train (21) over the stud (93). Align the air train (21) with the upper edge of the view port opening in the Band Mask frame (17).



Fig. 6.32 Install the air train.

5) Place the washer (23) on the stud (93) install and tighten the nut (22) to the correct torque. (see Appendix 1 for Torque Specifications.)

6) Test the side block prior to diving to ensure that no silicone sealant (RTV) is blocking the air flow to the Band Mask. If it is, it must be cleaned out prior to diving.

! DANGER: If silicone sealant is blocking the air flow into the Band Mask it must be cleaned out. If it is not the diver may not be able to properly defog the Band Mask or clear a flooded Band Mask quickly. In addition, if the demand regulator is not delivering air properly, the diver cannot use the free flow system as a source of breathing gas.

**6.6 DEFOGGER VALVE
(83 THROUGH 92)**

**6.6.1 Disassembly of the Defogger Valve
(83 through 92)**

Tools Required:
 3/8 inch Slotted Flat Blade Screwdriver
 13/16 inch Open End Attachment on Torque Wrench

NOTE: A slotted screwdriver is made by grinding a small v in the blade of a flathead screwdriver. This allows the knob locknuts to be loosened or tightened while allowing for the threaded stem end.

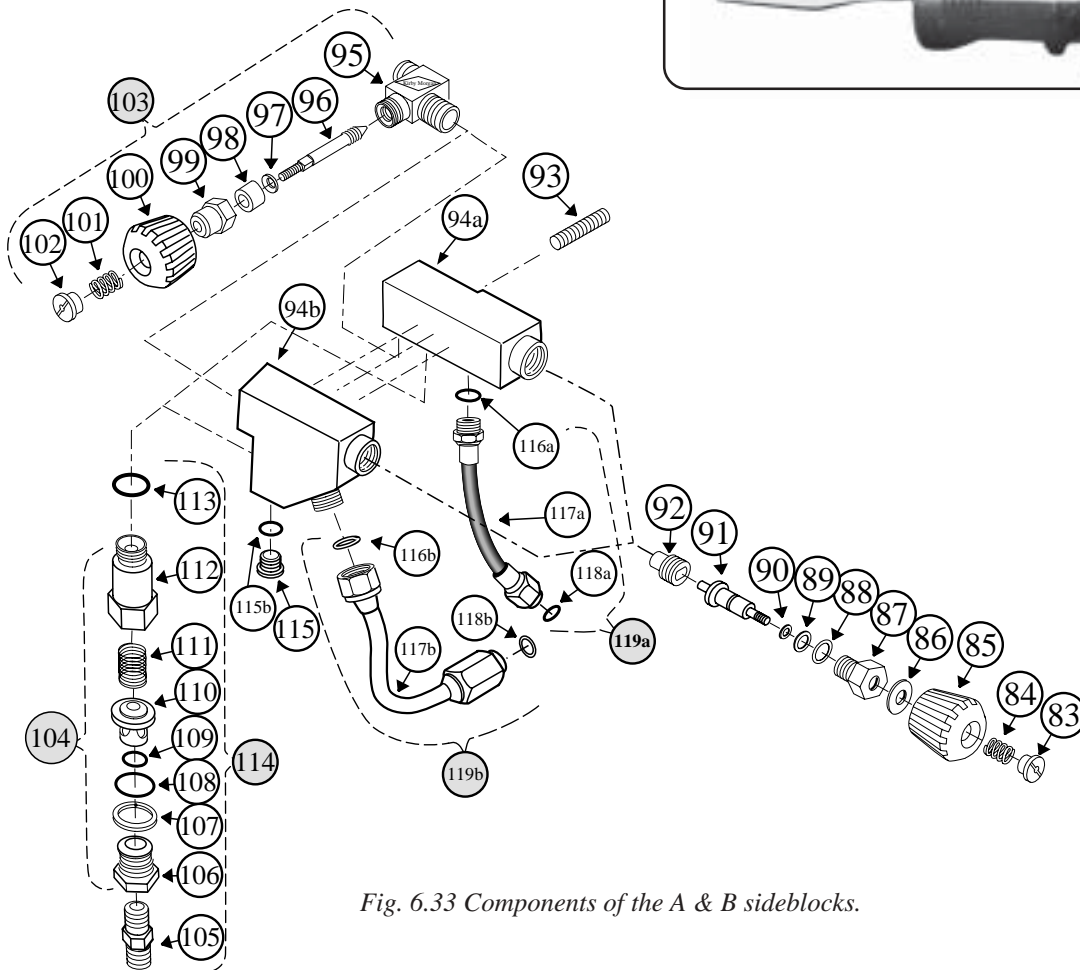



Fig. 6.33 Components of the A & B sideblocks.

The defogger valve components (83 through 92) are disassembled as follows:

1) First, unscrew the locknut (83) with the slotted screwdriver and remove the spring (84), control knob (85), and washer (86).

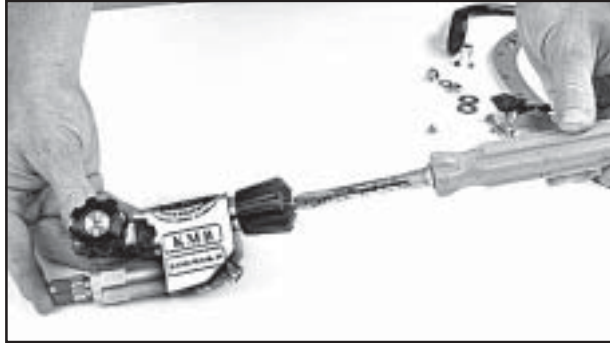

Fig. 6.34 Removal of the free flow knob.

2) Next, unscrew the bonnet (87). Its O-ring (88) will come off with it. The valve stem (91), O-ring (90), and washer (89) usually come out with the bonnet (87) and can be pushed out of the bonnet (87) once removed from the side block body (94a/b).



Fig. 6.35 Removal of the valve bonnet.

3) If the stem (91) remains in the side block body (94a/b) it can be lifted out after the bonnet (87) is removed.

4) The seat assembly (92) can be unscrewed from the side block body (94a/b) with the stem (91) or a screwdriver.



Fig. 6.36 The seat should be removed from the side block for inspection.

6.6.2 Cleaning and Lubricating

- 1) Clean all the metal parts in a dilute solution of white vinegar. Rinse in fresh water.
- 2) Check the plastic seat (92) for wear, and replace if necessary.
- 3) The Teflon washer (89) and O-ring (90) must be replaced if worn. Replace the O-ring (88) if worn.
- 4) Be sure to place a light coating of silicone grease on all internal moving parts, O-rings, and washers.

6.6.3 Reassembly of the Defogger Valve (83 through 92)

- 1) Screw in the seat assembly (92) until it is about even with the front of the side block body (94a/b).
- 2) Next, install the O-ring (90) and washer (89) onto the stem (91).

KMB 18 & 28 MANUAL

3) Insert the proper end of the stem (91) into the seat assembly (92) and turn clockwise until the seat (92) lightly bottoms out. Leave the stem in place.

4) Lubricate the O-ring (88) and install on the bonnet (87).

5) Slide the bonnet (87) over the stem (91) and thread the bonnet (87) into the side block (94a/b).

6) Next, tighten the bonnet (87) until it has firmly seated against the side block (94a/b) and torque to the proper torque setting. (see torque specs, pg 89)

7) Place the washer (86) and control knob (85) on the stem (91) and rotate the stem counterclockwise until the seat assembly (92) tops out fully open, then turn clockwise until fully closed. The control knob (85) must turn smoothly without any binding. Binding (or "hard spots") in the rotation could be an indication of a bent stem (91) that should be replaced.

8) Install the washer (86), knob (85), spring (84), and locknut (83). The locknut (83) must be run in with a screwdriver until the threaded end of the valve stem (91) is flush with the top of the locknut or protrudes slightly. (Use your slotted screwdriver for this step.)

6.7 AUXILIARY GAS SUPPLY VALVE ASSEMBLY (103)

The auxiliary valve assembly (103) on the Kirby Morgan Band Mask 18A/B and 28 is not built into the side block (94a/b). It is a separate component that can be removed and replaced, or disassembled in place on the side block assembly

(120a/b). This design differs from previous auxiliary valve designs in that it provides a higher flow, but works on similar principles.

6.7.1 Disassembly of the Auxiliary Valve (103) Assembly

Tools Required:

11/16 inch Open End Attachment on Torque Wrench

3/8 inch Slotted Flat Blade Screwdriver

1 inch Open End Attachment on Torque Wrench
Soft jaw vice

1) Remove the locknut (102), spring (101), and knob (100).

2) Undo the packing nut (99). When the packing nut is free of the threads of the auxiliary valve body (95), back out the stem (96) until it is free of the auxiliary valve body (94).

3) Remove the packing nut (99), packing (98), and washer (97) from the stem (96).

6.7.2 Cleaning and Lubricating

1) Clean all the metal parts in a dilute solution of white vinegar. Rinse with fresh water.

2) Inspect the packing (98) and washer (97) for wear and replace if necessary.

3) Inspect the stem (96) seat for unevenness or wear and replace if necessary. It must also be replaced if it is bent.



Fig. 6.37 Disassembly of the auxiliary valve.

4) Check the seat in the auxiliary valve body (95) for wear or unevenness. Replace the body (95) if necessary.

5) On the Kirby Morgan Band Mask 18B and 28, to remove the auxiliary valve body (95) from the side block (94a/b) the one-way valve assembly (114) must first be removed, as per Section 5.5.3.

6) On the Kirby Morgan Band Mask 18A, not only must the one-way valve assembly (114) be removed, but you must also remove the regulator hose assembly (117a) as per Section 6.8.1

6.7.3 Reassembly of Auxiliary Valve (103)

1) With the exception of the tapered pipe thread end of the auxiliary valve body (95), lubricate all components with a light coating of silicone grease.

2) Apply 1 1/2 wraps of 1/2 inch Teflon tape to the tapered pipe thread end of the auxiliary valve



Fig. 6.38 The tapered pipe thread end of the auxiliary valve must be wrapped properly with Teflon tape prior to installation.

body (95) prior to installing it in the sideblock (94a/b). Be sure the Teflon tape does not extend over the opening of the valve. There must be no loose bits of tape in the opening of the sideblock. Tape particles can interfere with the proper function of the breathing apparatus and may block the diver's air supply. After the auxiliary valve is mounted in the side block, the one-way valve and regulator hose (on the Kirby Morgan Band Mask 18A) may be reinstalled.

⚠ DANGER: Take care not to allow any pieces of Teflon tape to enter the side block. If these pieces of tape enter the demand regulator assembly and/or defogger valve they may block the flow of air to the diver. This could lead to death through suffocation.

3) Place the washer (97) and packing (98) on the stem (96).

4) Holding these components in place on the stem (96), screw the stem into the auxiliary valve body (95).



Fig. 6.39 Screw the stem into the auxiliary valve body.

5) Rotate the stem (96) until it is seated all the way in, then back it out about 1/2 turn.

6) Start threading the packing nut (99) onto the body (95). Run the nut in and tighten slightly with a wrench.

7) Place the knob (100) onto the stem (96) and rotate the stem all the way out, then back again. The rotation must be smooth. If "hard spots" or unevenness are felt during the rotation, the stem (96) may be bent and could need replacement.

8) Tighten the packing nut (99) with a wrench until friction, or moderate resistance is felt when turning the knob (100).

KMB 18 & 28 MANUAL

9) Place the spring (101), and locknut (102) onto the stem (96) securing the knob (100).

10) Tighten the locknut (102). The assembly is now complete and ready for testing.

11) Test the valve by attaching it to an auxiliary air supply source. There must be no leakage of gas past the stem (96) or through the packing nut (99). Turn on the bailout bottle and leave the supply on for several hours. There must be no drop in pressure in the system if the valve is operating properly.



DANGER: A leaking auxiliary valve assembly can cause the diver to exhaust his entire auxiliary air supply (bailout) without his knowledge. This may lead the diver to mistakenly assume his bailout supply is available when it is not. This could lead to panic or drowning in an auxiliary. Any worn component that causes an auxiliary valve to leak must be replaced.

6.8 MODEL “A” REGULATOR HOSE ASSEMBLY (119A)

The Kirby Morgan Band Mask 18A has a hose assembly (119a) for gas flow that connects the side block (94a) to the inlet nipple (61a) of the demand regulator (63a). The demand regulator (63a) end of the regulator hose assembly (119a) has a swivel type fitting that allows removal without rotating the hose.

6.8.1 Hose Removal

Tools Required:

9/16 inch Open End Attachment on Torque Wrench

13/16 inch Open End Attachment on Torque Wrench

11/16 inch Open End Attachment on Torque Wrench

O-ring Removal Tool

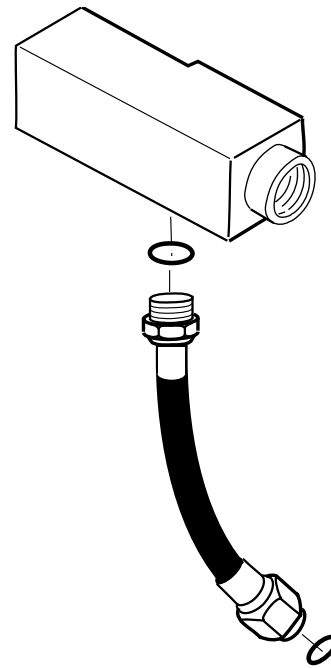

Fig. 6.40 The “A” side block.

1) Always start removal at the demand regulator (63a) end of the hose.

2) Once the hose nut is free from the inlet nipple (61a), the hose and fitting can be pulled out and is free. Be sure to use a backup wrench when removing the hose.

3) The side block (94a) end of the hose assembly (119a) can now be unscrewed, rotating the hose with the fitting.

6.8.2 Inspection, Cleaning, and Lubricating

1) Inspect the side block end O-ring (116a) and replace if necessary.

2) The regulator end O-ring (118a) is difficult to inspect. These O-rings seldom present problems and must be replaced on a time schedule at least once each year or whenever suspect due to any bubble leakage. This regulator end O-ring (118a) is removed by an O-ring removal tool.



Fig. 6.41 Removing an O-ring from an "A" regulator hose.

3) Once removed discard, as damage to this O-ring (118a) is unavoidable. Installation of a new O-ring is simple. Wipe with a light silicone grease coating, stretch onto the fitting, and slide until the O-ring (118a) snaps into the groove.

6.8.3 Hose Replacement (117a)

1) Always install the side block (94a) end first, and the regulator inlet nipple (61a) end last. Use a backup wrench on the nipple.

2) Tighten the side block end and tighten the regulator end.

3) Test for leaks prior to use.



Fig. 6.42 Replacing an "A" regulator hose.

KMB 18 & 28 MANUAL

6.9 “B” BENT TUBE ASSEMBLY (119B) (KMB 18B AND 28)

6.9.1 General

The Kirby Morgan Band Mask 18B and 28 bent tube assembly (119b) for gas flow that connects the side block (94b) to the inlet nipple (61b) of the demand regulator assembly (63b). Both ends of the bent tube assembly (119b) disconnect for complete removal.

6.9.2 Removal of the Bent Tube Assembly (119b)

Tools Required:

11/16 inch Open End Attachment on Torque Wrench

7/8 inch Open End Attachment on Torque Wrench

7/8 inch Open End Wrench

1) Always start removal at the side block assembly end. The free swiveling mount nut is unthreaded completely and can slide down the tube.

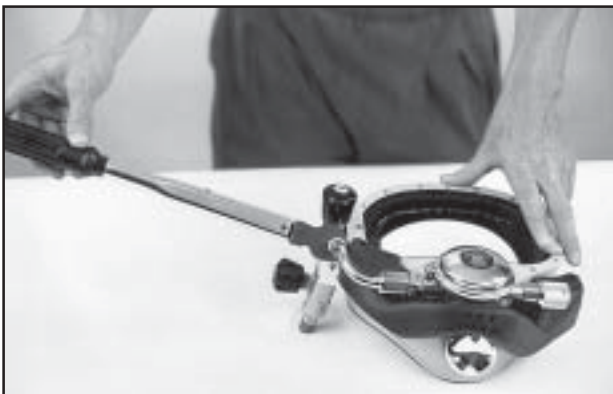

Fig. 6.43 Always start removal of the bent tube at the side block end of the tube.

2) The regulator (63b) end has a jam nut (61c) that locks the mount nut in place. With one wrench, hold the bent tube mount nut. With another wrench, turn down the jam nut (61c), backing it away from the mount nut. The mount nut can then be rotated until free of the regulator inlet nipple (61b) threads. It can be pushed up on the bent tube.

3) With the two mount nuts free, the bent tube assembly (119b) can be pulled straight out of the regulator inlet nipple (61b). The bent tube assembly (119b) can be rotated back and forth to aid removal. Be careful to only rotate and pull out straight. **DO NOT BEND THE TUBE.**

6.9.3 Inspection of Bent Tube Assembly (119b)

The O-ring (118b) at the regulator end is inspected and replaced if necessary. The Teflon O-ring (116b) at the side block end is inspected and replaced if necessary.

! DANGER: Be sure to use only Kirby Morgan Genuine Parts when repairing your Band Mask. The use of other manufacturer's parts may interfere with the proper performance of your mask and jeopardize your safety.



Fig. 6.44 Inspect the Teflon O-ring on the bent tube and replace if needed.



Fig. 6.45 Replace the O-ring on the bent tube if it is worn.

The bent tube (117b) must be free of dents. If the Band Mask has been used for burning (underwater cutting) jobs, carefully check for erosion of the metal. Replace tube if necessary.

6.9.4 Replacement of the Bent Tube Assembly (119b)

1) It may be necessary to loosen the demand regulator mount nut (8) before installing a new bent tube assembly (119b). This may need to be done for alignment when starting the mount nut onto the side block (94b).

2) After loosening the mount nut (8), lightly lubricate the O-ring with silicone lubricant and push the O-ring end of the bent tube assembly into the regulator inlet nipple (61b). Slide it in until the side block (94b) end is aligned with the threads for the mount nut.



Fig. 6.46 You will probably need to loosen the regulator mount nut to position the bent tube.

3) Be sure the Teflon O-ring (116b) is in place.

4) Start to tighten the bent tube assembly (119b) mount nut on the side block end.

5) Next, tighten the regulator mount nut (8) securing the regulator to the Band Mask frame (17).

6) Start the bent tube mount nut onto the inlet nipple (61b). Run it in **HAND TIGHT ONLY**.

7) Tighten the side block end nut.

8) Hold the nut on the end of the bent tube (117b) with a wrench and tighten the jam nut (61c) to the correct torque against it with another wrench. The jam nut must not be bottomed out against the nipple (61b).



Fig. 6.47 Tightening the jam nut.

KMB 18 & 28 MANUAL

6.10 NOSE BLOCK ASSEMBLY (3 AND 32-34)

6.10.1 Nose Block Assembly Removal

Tools Required:

Slip Joint Pliers

Rag or cloth

7/16 inch Open End Wrench



Fig. 6.48 Removal of the nose block knob.

1) Hold the nose block knob (34) with a pair of pliers (padded by a cloth) while unscrewing the nose block device (3) with your other hand inside the mask at the pad end.

2) After the knob (34) is removed, loosen and remove the packing nut (33).

3) Slip the two O-rings (32) off the end of the shaft of the nose block device (3).

4) The pad end of the shaft may be bent with pliers to better fit an individual. A larger pad of rubber can also be glued onto this pad or stretched into place.

6.10.2 Nose Block Device (3) Replacement

1) Prior to reassembly, lubricate the two O-rings (32) with silicone grease.

2) Slide the shaft (3) through the Band Mask frame (17).

3) Place both O-rings (32) on the shaft (3), followed by the packing nut (33) and the knob (34).



Fig. 6.49 Be sure to reinstall the nose block device O-rings.

4) Tighten the packing nut (33) until snug. **DO NOT OVERTIGHTEN AS THIS WILL MAKE IT DIFFICULT TO SLIDE THE NOSE BLOCK DEVICE IN AND OUT.**

5) Tighten the knob (34) with the pliers while holding the shaft (3) with your hand at the pad end inside the mask.

6.11 BAND MASK FRAME KMB 18A/B

The Band Mask frame (17) on the KMB 18A/B is constructed by hand of fiberglass cloth, fiberglass mat, and fiberglass strands impregnated with polyester resin. It is strong and extremely durable.

A polyester color coat covers the exterior of the unit. Although this color is more durable than paint, it can be scratched and chipped. Light scratches can be removed using automotive rubbing compound and waxing.

! **DANGER:** Do not attempt to install new thread inserts in the frame for the port retainer screws! If the installation is done improperly, the port retainer can come loose and the Band Mask could flood. This could lead to drowning. Return the Band Mask to KMDSI for inspection and repair of threaded inserts.

NOTE: It is necessary to first remove the regulator and exhaust assembly from the helmet to replace the exhaust valves. See Section 6.7.5.

6.12.2.1 Tri-Valve™ Exhaust Valve Replacement.

- 1) Remove the Tri-Valve™ Assembly (Sec. 6.9.1)
- 2) Using small cutting pliers, carefully cut & remove the two Tie Wraps (35f) that hold the Deflector Whiskers™ (35a,35b) to the main exhaust body (35c).
- 3) Remove the 2 Exhaust Valve Inserts and Valves. (35d, 35e). **CAREFULLY NOTE** which side the valves are installed into and which way they face when mounted in the body. They **MUST** be reinstalled facing the same way. See Fig. 6.51
- 4) Install a new exhaust valve (35e) into each whisker exhaust valve insert (35d) on the correct side (see Fig. 6.51) by feeding valve tail through hole in center of valve insert and pulling on it until valve is seated

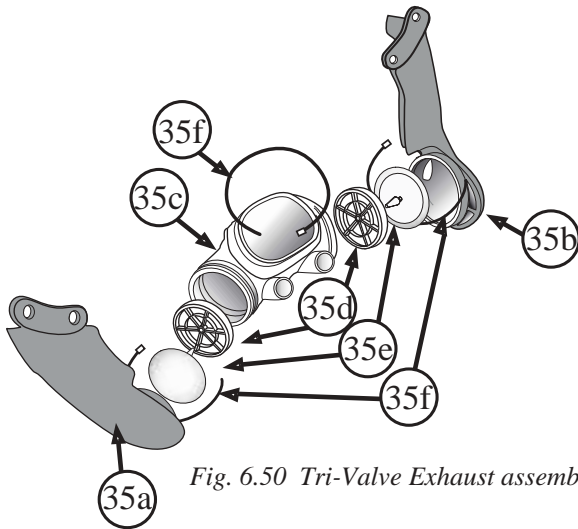

Fig. 6.50 Tri-Valve Exhaust assembly.

6.12 TRI-VALVE™ EXHAUST ASSEMBLY

6.12.1 Tri-Valve™ Assembly Removal

Tools Required: Screwdriver
Small cutting pliers

NOTE: It is necessary to first remove the regulator and exhaust assembly from the helmet to remove the Tri-Valve™ Assembly from the regulator. See Section 6.7.5.

- 1) The Tri-Valve™ Assembly is removed by cutting the Tie Wrap that holds the assembly to the regulator. After removing the Tie Wrap, remove the Tri-Valve™ Main Body by stretching it over and off of the Regulator Exhaust Flange.

6.12.2 Tri-Valve™ Exhaust Valve and Regulator Exhaust Valve Replacement.

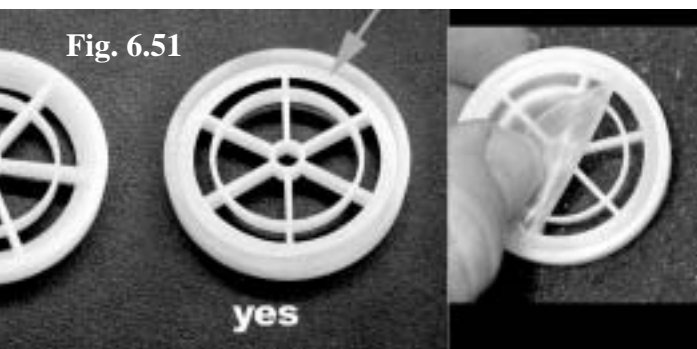

NOTE: The exhaust valve/whisker exhaust valve inserts assembly must be placed into Tri-Valve exhaust main body correctly to provide gas flow in the proper direction. The flow must be from the inside of tri-valve exhaust main body out to starboard whisker (35a) and port whisker (35b).

- 5) Install an exhaust valve/whisker exhaust valve insert assembly into both seating areas on each side of tri-valve exhaust main body.

KMB 18 & 28 MANUAL

6) Slide the starboard whisker (77b) onto the starboard side of the main body (77a), making sure that you do not dislodge exhaust valve/whisker exhaust valve insert assembly from its seating area. The parting line on bottom of the exhaust whiskers should be $\frac{5}{16}$ " behind parting line on the main body. See Fig 6.52



Fig 6.52

7) Repeat this procedure for the Port Side.

8) Place tie-wraps (77f) around the tie wrap grooves in each of the two whiskers. Before doing the final tightening of the tie-wraps, make sure that parting line on bottom of wings is $\frac{5}{16}$ " behind parting line on the main body, (See Fig 6.52) and the heads of the tie wraps are positioned on the body as shown below.



6.12.2.2 Regulator Exhaust Valve Replacement.

1. Before removing the regulator exhaust valve (104), carefully inspect the area around the edges to assure the rubber exhaust valve is in contact with the regulator body. The metal cross area of the body under the valve could be slightly bent out resulting in the valve not sealing. If the exhaust valve is high and not sealing, lightly

press in on the metal cross, bending the metal in slightly until the rubber valve seats. Remove the existing Regulator Exhaust Valve by pulling it out of its mount hole. If the Valve tears, make sure that is removed without any valve material is left in the inside of the regulator.



NOTE: Before installing the new Valve, ensure that the spokes that hold the exhaust Valve are smooth, even and not bent. The Exhaust Valve seating area should be free of dirt and corrosion to insure the valve can lay flat and seal properly. **NEVER lubricate the valve.**

2. Remove the Clamp Screw and Clamp

3. Remove the Cover and the Diaphragm

4. Install the new Regulator Exhaust Valve by placing the stem of the Valve in through the hole in the hub of the spokes from the outside of the Regulator. Gently, (using needle nose pliers) from the inside of the regulator, pull the stem of the valve through the hole in the hub of the spokes until it pops into its seating area.

5. Reinstall the Diaphragm, Cover, Clamp and Clamp Screw.

6.12.3 Tri-Valve™ Assembly Installation

1. The Tri-Valve Main Body opening mates to the Regulator Exhaust Flange. This opening needs to be worked onto the flange. Make sure that the Tri-Valve Exhaust System is facing the correct direction and is not upside down.

2. Place the Tie Wrap around the Tie-Wrap seating surface and tighten. Cut off the excess Tie Wrap tail.

3) Reinstall the regulator/Exhaust Assembly on the mask.

6. 13 MAIN EXHAUST ASSEMBLY (64-67, 69)

The main exhaust assembly (64-67) is held in place by the three screws (69) that are installed from the inside of the mask frame. Silicone sealant (RTV) is used to seal the main exhaust body (67) to the mask frame (17) on the KMB 18. On the KMB 28 there is no main exhaust body. The seat for the rubber exhaust valve is molded into the mask frame.

6.13.1 Exhaust Valve (66) Removal

Tools Required:
Flat blade screwdriver

1) The cover (65) is removed by unscrewing the two screws (64). If the cover is badly dented so that it interferes with the performance of the exhaust valve (66) it must be replaced.

2) The valve (66) must be replaced at the slightest sign of deterioration or aging of the rubber. Simply grasp the valve and pull to remove.



Fig. 6.55 The main exhaust valve exposed on the KMB 18.



Fig. 6.56 Note how the main exhaust body is molded into the frame on the KMB 28.

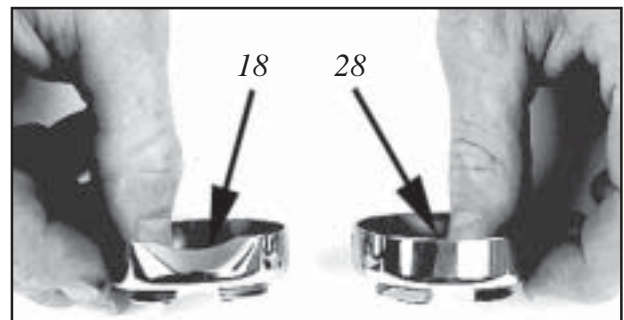

Fig. 6.57 Note the difference between the exhaust covers for the KMB 18 and 28. The cover for the 18 is on the left, while the 28 is on the right.

3) Replace the exhaust valve (66) by feeding the tail of the new valve into the hole in the center of the body and pulling it through until the stem seats. The excess tail may be trimmed off.

3) The main exhaust body (67) on the KMB 18 should never need servicing, unless the seal is broken between the silicone sealant (RTV) and the body (67) and mask frame (17). On the KMB 28 the main exhaust body is molded into the mask frame.

! CAUTION: Over tightening the exhaust cover screws on the KMB 28 could damage the threads in the exhaust body. This body is not replaceable and could require the replacement of the entire mask frame.

KMB 18 & 28 MANUAL

6.13.2 Main Exhaust Body (67)

Replacement

If the seal is broken between the main exhaust body (67) and mask frame (17) on the KMB 18 the body should be removed and reinstalled.

1) Remove the body (67) by unfastening the three screws (69). Clean off all traces of the silicone sealant from the outside of the mask frame (17) and main exhaust body (67).

2) Apply fresh silicone sealant to the main exhaust body (67) where it contacts the mask frame (17). Take care to prevent any silicone sealant from entering the main body (67) as this would interfere with the proper performance of the main exhaust valve (66).

⚠ DANGER: Be sure to use the correct length screws when mounting the main exhaust cover. Longer screws could obstruct the exhaust and cause the mask to leak. This could lead to drowning. Use only Kirby Morgan Genuine Parts.

3) Position the body (67) on the mask frame (17) and tighten the screws (69) to 13 inch pounds of torque.

6.14 DEMAND REGULATOR ASSEMBLY (63A/B)

6.14.1 General

The regulator system on the Kirby Morgan Band Mask 18A/B is simple and highly reliable. However, inhalation resistance may be high if not maintained properly.

If the regulator does not breathe easily, the diver cannot work hard and will tire rapidly. Simply put: If the demand regulator does not work properly the diver cannot work properly. This makes the maintenance of the demand regulator assembly essential.

For the gas inlet valve and adjustment system to operate properly, the components in the demand regulator **MUST** be in good condition and **MUST** be periodically adjusted internally.

Special tools should be used to work on the regulator. Disassembly, assembly, and adjustment can be done without these tools, but the work is much easier and the adjustment is better if these tools are used. The tools are available together along with a tool pouch. The tool kit with pouch is KMDSI Part #525-620.



Fig. 6.58 The regulator tool kit KMDSI #525-620

6.14.2 Demand Regulator Assembly (63A/B) Removal

Tools Required:

- 1 1/4 inch Socket on Torque Wrench
- 1/4 inch Flat Blade Attachment on Torque Screwdriver
- 11/16 Open End Attachment on Torque Wrench
- 13/16 Open End Attachment on Torque Wrench
- 2 ea. 7/8 inch Open End Attachment on Torque Wrench

1) To remove the regulator from the Band Mask, the hose assembly (119a) on the Kirby Morgan Band Mask 18A, or the bent tube assembly (119b) on the Kirby Morgan Band Mask 18B or 28 must be removed first.



Fig. 6.59 Use the proper socket to remove the regulator mount nut.

2) The hose assembly (119a) may be removed from the regulator inlet nipple (61a) only and left attached to the side block assembly (119a). Be sure to use a backup wrench during this operation. The bent tube assembly (120b) must be removed entirely before regulator removal. (See Section 6.9.2).

3) Remove the whisker (35) as per section 6.12.1.

4) The regulator mount nut (8) is removed with the sealing O-ring (7).

5) Now the regulator assembly (63a/b) can be pulled out of the Band Mask.



Fig. 6.60 The regulator mount nut.

6.14.3 Disassembly of the Demand Regulator (63A/B)

Tools Required:

1/4 inch Flat Blade Screwdriver Attachment on Torque Wrench

KMDSI Regulator Tool Kit, KMDSI Part #525-620

7/8 inch Open End Attachment on Torque Wrench

3/4 inch Open End Attachment on Torque Wrench

3/32 inch Punch

7/8 inch Open End Wrench

Small Ball Peen Hammer

1) Remove the cover clamp screw (49) and cover clamp (50).

2) Lift the cover (51) off and take out the diaphragm (52). If the purge button is to be replaced, using external retaining ring pliers, remove the retaining ring (51a), spring (51c) and button (51d) from the cover.

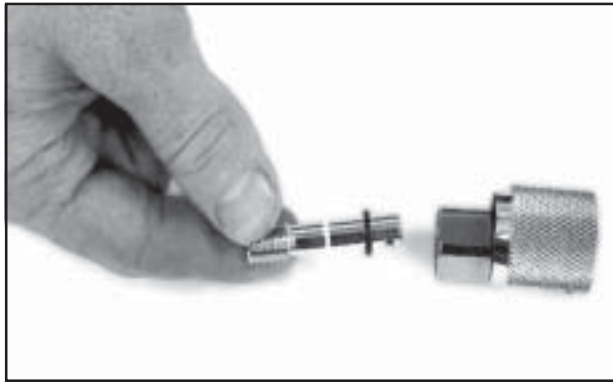

Fig. 6.60 Separating the adjustment knob from the stem.

3) Adjustment knob removal is started by unscrewing the adjustment knob (47) until it stops.

4) The packing nut (46) is now exposed enough to use a wrench on it for removal. As the nut (46) is backed off, unscrew the knob (47), also.

5) The O-ring (45) and washer (44) remain on the shaft (43).

6) If the washer and O-ring need to be replaced, place the adjustment knob (47) on a block of wood and drive the retaining pin (48) out with the 3/32" punch. (see section 5.5.5.1 #3)

7) Tilt the Band Mask so that the spacer (42), spring set (41), and piston (40) fall out of the adjustment shaft tube.

8) If not already done, remove the hose assembly (117a) or bent tube assembly (117b), as per Section 6.8.

9) Depress the roller lever (55) while unscrewing the inlet nipple (61a/b) so as not to scar the seat. Remove the inlet nipple (61a/b) from the regulator body (39).

10) Inside the regulator body (39), remove the nut (53) from the inlet valve (59). The inlet valve (59) must be held to prevent rotation when the nut (53) is being unscrewed. The castle wrench may be used to hold the inlet valve while the nut is unscrewed. Insert the castle wrench into the inlet nipple and press it onto the inlet valve. Also, the

inlet valve holder tool can be used to hold the inlet valve by inserting it through the balance hole in the inlet tube and wedging it against the inlet valve stem. These tools are included in the KMDSI Tool Kit, KMDSI Part #525-620.

11) Remove the nut (53) completely. The socket wrench, KMDSI Part #525-612 can be inserted into the adjustment tube for removal of the nut (53).

12) Tilt the regulator and drop out the inlet valve (59) spring (58), and washer (57).

13) The spacer (54), lever (55), and washer (56) will now fall out of the regulator body (39). The spacer 42, Spring set (41) and piston (40), can be removed from the opposite side of the regulator.

6.14.4 Inspection of Demand Regulator (63a/b) Parts

After the regulator has been disassembled, carefully clean and inspect all parts. If parts show signs of wear or damage they must be replaced, even if it is prior to the recommended replacement interval.

1) Inlet valve (59): Check for rough surface, cuts, and deep depressions. Check the knife edge of the inlet nipple seat (61 a/b) for nicks, dents, or flat spots. Use your fingernail to feel for nicks. Replace the inlet valve and/or inlet nipple if damage is found.

2) Diaphragm (52): Check to determine if rubber has separated from the metal part. Inspect for cracks, pin holes, and pinching of outer edges.

3) O-rings (45, 60, 7): Check for irregularities in the rubber. Check for cracking.

4) Exhaust valve (62): Be sure there is no curling or deformation and that the rubber is in good shape.

5) Inspect the whisker. Replace the whisker (35) if it shows wear or aging. Replace the whisker if it allows bubbles to interfere with visibility.

6) Inspect the regulator body (39). Check the brazed joints for cracks. Make sure that the adjustment tube and inlet tube are in alignment. They can become bent if the mask is dropped. Replace the body if there is any sign of damage. Make sure the outer circumference is round and has no flat areas from damage.

6.14.5 Reassembly of the Demand Regulator (63A/B)

1) Press the head of the inlet valve (59) into the castle wrench (KMDSI Part #525-618). Load the spring (58) and brass washer (57) onto the inlet valve (59). With the inlet valve securely held, insert it into the inlet tube in the regulator body (39). The shaft of the inlet valve (59) will protrude into the interior of the regulator body (39).

2) Place the washer (56) onto the shaft of the inlet valve (59) rough side towards the regulator body.



Fig. 6.62 Press the head of the inlet valve (59) into the castle wrench

⚠ CAUTION: This washer (56) is a stamped part. One side is smooth and the other side may have rough edges. Load the washer (56) onto the inlet valve shaft (59), rough side first, so that the rough side will seat against the regulator body (39). The smooth side will be out for the lever (55) to act against. This will assure smoother regulator operation.

3) Place the spacer (54) onto the shaft of the inlet valve (59).

4) Load a new locknut (53) into the socket of the socket wrench from the KMDSI tool Kit. Insert it through the adjustment shaft tube and run the nut onto the inlet valve stem (59) for approximately two threads to leave room for the installation of the lever (55).

⚠ WARNING: The lock nut (53) must always be replaced if removed from the inlet valve (59). The plastic material that locks the nut from unscrewing is not designed for multiple reuse. If the nut was to come loose this would cause the regulator to reduce flow or supply no air to the diver. Although the diver could still breathe by manually operating the free flow on the side block, this could cause panic.

5) With the inlet valve (59) pushed in, the spacer (54) and washer (56) should be loose on the inlet valve shaft (59).

6) The lever (55) is installed next between the spacer (54) and the washer (56). The lever legs **MUST** be parallel to each other. Use a straight edge to make sure the legs are in line. Bend with pliers if necessary.

7) Hold the inlet valve (59) with the castle wrench and tighten the nut (53) until two threads are visible past the nut (53).



Fig. 6.63 Use the KMDSI socket wrench to turn the nut on the inlet valve.

KMB 18 & 28 MANUAL

8) While holding the lever (55) down, install the inlet nipple (61a/b) with its O-ring (60) into the regulator body (39) and tighten to correct torque. (see torque specs pg 89)

9) Install the piston (40), spring set (41), and spacer (42) into the adjustment tube of the regulator body (39) as shown in the blow apart drawing. Lubricate this assembly lightly.

10) If you have disassembled the adjustment knob (47), next, slide the washer (44) and the O-ring (45) onto the adjustment shaft (43).

11) Slide the packing nut (46) onto the shaft (43), then slip the knob (47) onto the end of the shaft.

12) Holding the shaft (43), rotate the knob (47) until the pin holes line up.

13) Install the retaining pin (48) by tapping it in with a light hammer until the end of the pin is flush with the knob surface.

14) Thread the adjustment shaft (43) into the tube until the packing nut (46) can be started.

15) Tighten the packing nut (46) to the correct torque (see pg 89). Make sure the adjustment knob (47) is run in simultaneously.

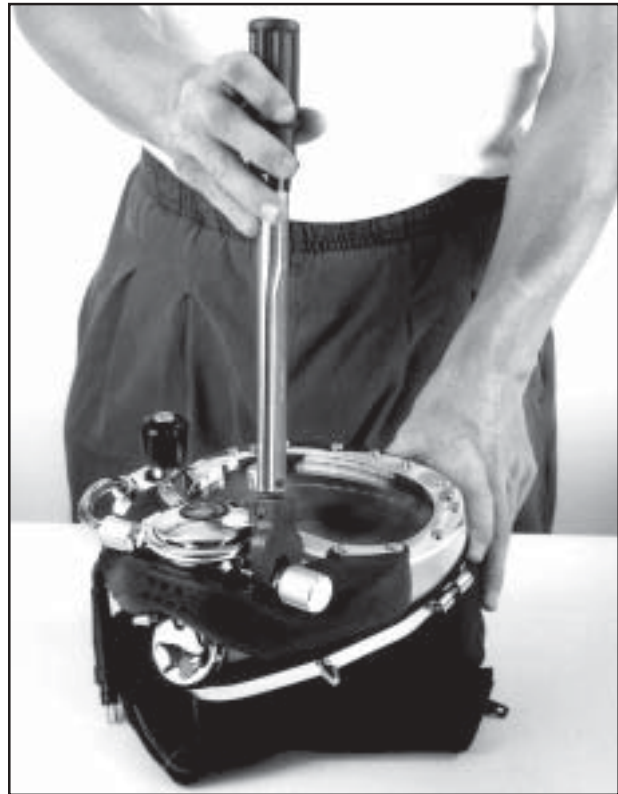

Fig. 6.64 Tighten the packing nut.

16) Check the adjustment knob (47) for free rotation and run in slightly. If the regulator needs adjustment, see Section 5.6 for adjustment.

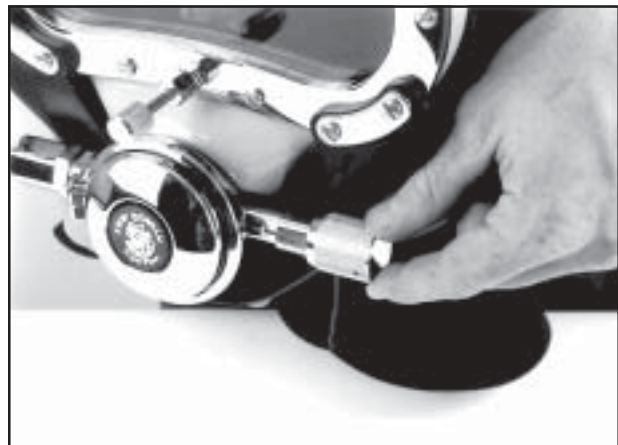

Fig. 6.65 The adjustment knob must turn freely.

17) Replace the diaphragm (52).

18) If you have disassembled the purge button assembly, install the button (51d) and spring (51c) into the cover (51b) and replace the retaining ring (51a) using external retaining-ring pliers. Note that the flat side of the retaining ring faces away from the face of the button.

19) Screw the clamp (50) back together with the cover in place (51).

20) Stretch the whisker (35) onto the exhaust flange of the regulator.

21) Mount the regulator to the Band Mask frame (17). Make sure the sealing O-ring (7) is in place under the regulator mount nut (8).

22) If the Band Mask is a “B” model, do not tighten the mount nut (8) until after the bent tube assembly (120b) is installed on the regulator, inlet nipple (61b), and the side block body (94b). Tighten the mount nut (8) until the O-ring (7) is compressed and the nut contacts the Band Mask frame. Further tightening will damage the Band Mask frame (17).

23) On the “A” models the regulator mount nut (8) may be tightened before installation of the hose assembly (119a). Use a backup wrench for this operation.

24) Assemble the hose assembly (119a) or bent tube assembly (119b) to the regulator (63a/b) and the side block (93a/b).

25) Attach the screws (38), plates (37) and spacers (36) on each side of the port retainer (28) and tighten to correct torque. (see pg 89)

Do not overtighten.

 **DANGER: Always be sure to use a torque screwdriver to check the tension of the port retainer screws. Overtightening can cause damage to the threaded inserts in the fiberglass frame and cause them to loosen. Without the correct tension the port retainer may come loose and the Band Mask could flood. This could lead to drowning.**

6.14.6 Unexplained Demand Regulator Steady Flow When Underwater

Any leak in the face seal will cause gas to vent out into the water. This causes the demand regulator to steady flow, making up for the vented gas. Even if the adjustment knob (47) is turned in, the leak may continue.

This type of regulator flow may be caused by a tear in the face seal, or if the face seal has separated from the hood. It can easily be repaired with wet suit cement. Both the hood and face seal (2) must be completely clean and dry prior to repairs.

KMB 18 & 28 MANUAL

6.15 ORAL NASAL MASK (9)

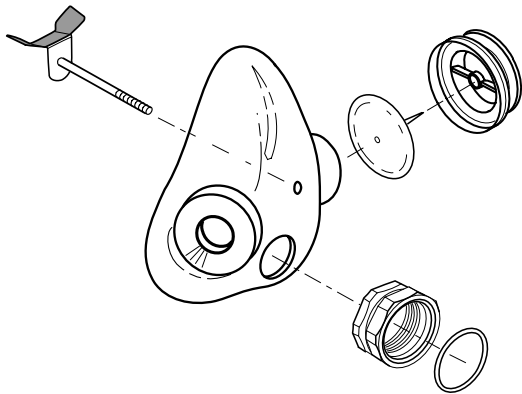

Fig. 6.66 The oral nasal mask.

6.15.1 Oral Nasal Mask (9) Removal

Tools Required:

7/16 inch Open End Wrench

The oral nasal mask (9) is easily replaced.

- 1) Remove the nose block device (3) first. See Section 6.3.2.
- 2) Remove the oral nasal microphone (12).
- 3) The oral nasal mask (9) can then be pulled off the regulator mount nut (8). It is held on by a snap fit.

6.15.2 Inspection of Oral Nasal Mask (9)

- 1) Inspect the oral nasal mask (9). If it is torn or rotting it must be replaced.
- 2) Inspect the oral nasal valve (5). If it is torn or rotting it must be replaced.

6.15.3 Oral Nasal Mask (9) Replacement

- 1) Snap the oral nasal mask (9) back over the regulator mount nut (8).
- 2) Reinstall the microphone (12).

- 3) Reinstall the nose block device (3) as per Section 6.3.3.

6.15.4 Oral Nasal Valve Replacement

- 1) Remove the valve body (53) by pushing it out of the oral nasal.
- 2) Remove the old valve (52) by pulling it out.
- 3) Install the new valve by feeding the thin tail through the valve body and pulling on it until the valve is seated.
- 4) Install the valve body in the Oral Nasal. The valve **MUST** be on the inside of the Oral Nasal.

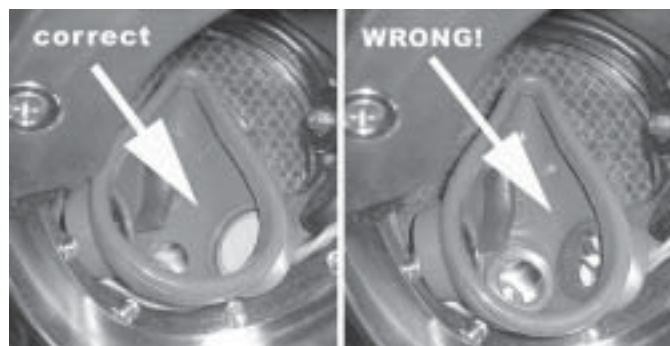

⚠ DANGER: The oral/nasal valve must be replaced correctly to provide gas flow in the proper direction. The flow through the valve must be from the interior of the helmet into the oral nasal mask. This will allow the diver to breathe the gas from the defogger valve freely, yet help to reduce carbon dioxide inside the helmet. If the valve is not replaced properly this could make it difficult to breathe the gas supplied by the defogger and expose the diver to an excess of carbon dioxide. This could lead to exhaustion and blackout.

ACCESSORIES

7.1 INTRODUCTION

This section provides the manufacturer's advice on how to install KMDSI accessories including the hot water shroud, low pressure inflator hoses, and the weld lens assembly.

7.2 HOT WATER SHROUD INSTALLATION PROCEDURES

The KMDSI Hot Water Shroud Kit only fits the "B" sideblock. The Hot Water Shroud (KMDSI Part #525-100) should be used whenever diving in water colder than 35.6 F (2 degrees C). The KMDSI hot water kit is designed to be integrated with a hot water supply to help maintain breathing gas temperature at an acceptable level for the diver. In addition the hot water reduces the possibility of ice forming in the demand regulator or gas train components. Even with water temperatures of 40 F (4 C) the diver can experience discomfort and severe heat loss through the respiration process. For this reason, KMDSI recommends installing the hot water shroud when diving in waters colder than 40 F (4 C). Water supply to shroud assembly should be at least 1 gallon (3.7 liters) per minute at a minimum temperature of 105 F (42C). When diving operations are conducted during severe cold surface temperatures a hot water shroud should be used to prevent ice from developing in and on gas train components while the diver is on the surface.

Tools Required:

1/4 inch Flat Blade Attachment on Locking Screwdriver

7/8 inch Open End Attachment on Torque Wrench

11/16 inch Open End Attachment on Torque Wrench

1) Disconnect the bent tube assembly (119b) at the side block end only. Loosen the jam nut (61c) at the regulator. If the bent tube will not swivel, loosen the large nut at the regulator.

2) Remove the locknut (83), spring (84) and free flow knob (85).

3) Remove the locknut (102), spring (101) and auxiliary valve knob (100).

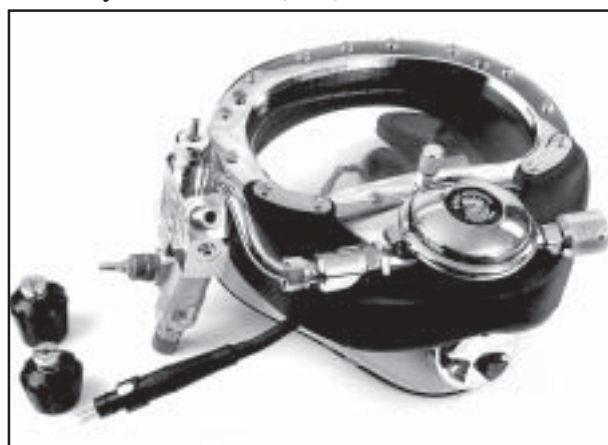

Fig. 7.1 Remove the auxiliary valve and free flow knobs to install the hot water shroud.

4) Screw the regulator adjustment knob (47) in all the way.

5) To install the rubber regulator cover, slide it over the bent tube assembly (119b) and stretch it over the regulator adjustment knob (47).



Fig. 7.2 Install the regulator cover.



Fig. 7.3 Install the side block cover.

6) Install the rubber side block cover. Start by inserting the one-way valve (104) through the square hole on the back side of the cover. All the other holes will then line up correctly.

7) Slide one of the PVC flanges over the bent tube (119b).

8) Install the second PVC flange in one end of the corrugated tube, (1/4 inch (6.0 mm) of the flange should still show).



Fig. 7.4 Install the PVC flanges.

9) Compress the corrugated tube and slide it over the bent tube (119b). The PVC flange previously installed in the corrugated tube mates with the side block cover.

10) Attach the side block end of the bent tube (119b) to the side block assembly (120b). Tighten with an 11/16 inch wrench.

11) Retighten regulator jam nut (61c). You will need to slide the PVC flange towards the side block.

12) Stretch the corrugated tube over the side block assembly (120b) and regulator cover.

13) Attach the tie wraps over the corrugated tube



Fig. 7.5 Attach the tie wraps.

at the PVC stiffeners and tighten.

14) Trim the excess ends from the tie wraps.

15) Reinstall the free flow knob (85), spring (84), and locknut (83).

16) Reinstall the auxiliary valve knob (100), spring (101), and locknut (102).

7.3 LOW PRESSURE INFLATOR HOSE INSTALLATION ON THE “B” SIDEBLOCK ASSEMBLY (120B)

The low pressure inflator system may be used with either conventional buoyancy compensators or dry suit systems. For certain pieces of equipment it may be necessary to use a longer inflator hose than is originally supplied by the manufacturer of the low pressure system. **The low pressure inflator port is not available on “A” masks.**

Tools Required:
5/32 inch Allen Wrench Attachment on Torque Wrench

- 1) Remove the l.p. plug (115) from the side block assembly (120b).

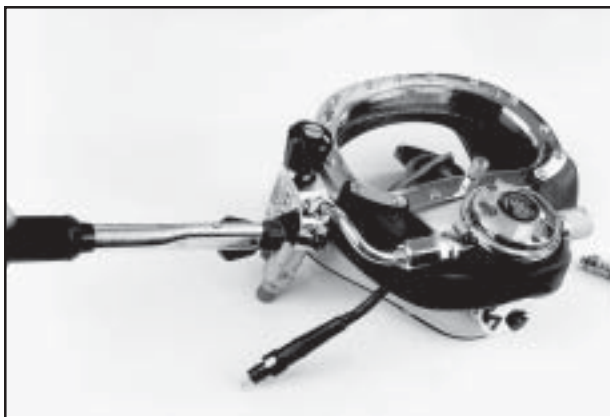

Fig. 7.6 Remove the plug from the side block to install the low pressure hose.

- 2) Check the O-ring on the low pressure whip to be sure it is present and in good condition. Carefully screw the low pressure whip into the side block.
- 3) Tighten fitting to the specifications provided by the dry suit manufacturer. Do not overtighten.
- 4) Pressurize mask and test connection for leaks.

⚠ CAUTION! When using the low pressure port on the side block for attachment of a low pressure hose, a hose with built in flow restriction or the KMDSI Flow Restrictor Adapter, KMDSI P/N 555-210 must be used.

7.4 WELD LENS/WELD SHIELD ASSEMBLIES INSTALLATION

Tools Required:
3/8 inch Open End Wrench
1/4 inch Flat Blade Attachment on Torque Screwdriver

- 1) Remove the two plug screws (29) from the port retainer (28).

For the remainder of the part locations refer to the drawing included with the weld lens or weld shield assembly kits respectively.

- 2) Insert the mount screws through the spacer washers and then through the mount ears.
- 3) With the rubber bumpers facing the inside of the helmet (weld lens), install and tighten the two mount screws into the port retainer.
- 4) Tighten the two lock nuts on the ends of the hinge studs (weld lens) so that the welding lens assembly can be flipped up, but not fall down from its own weight. The weld shield is pre-tensioned at the factory

Fig. 7.7 The weld lens assembly.



Fig. 7.8 The weld shield assembly.

⚠ DANGER: Use only the bolts provided with the Weld Lens Kit for installation of the assembly. Longer bolts will damage the mask frame and/or the threaded inserts. This could cause flooding through the port.

7.5 USE OF QUICK-DISCONNECT

A quick-disconnect should be used with all bailout systems. They are available through all KMDSI dealers. It provides greater convenience on deck while dressing the diver. It also makes it possible to separate the attachment of the bailout from the mask should the diver become entangled underwater.

The quick-disconnect is designed to be installed in any low pressure port of the diver's bailout regulator. The connector splits the hose into two halves, with a male and female connector on each end. The female connector is equipped with a sleeve lock that must be properly aligned before the hose can be disengaged.

One end of the connector is designed to be attached to the auxiliary valve assembly (103), while the other end of the connector is designed to attach to any of the standard low pressure ports on the KMDSI SuperFlow first stage regulator (or any high performance regulator) used for the bailout supply.



Fig. 7.8 A quick disconnect will make it simpler to hook up your bail-out to your mask.

7.6 MASK CARRYING BAG

To help protect your Kirby Morgan Band Mask the mask carrying bag should be used to transport and store your mask between jobs. The KMDSI bag is made from extra heavy duty, black, ripstop nylon. The bottom of the bag is padded for additional protection. Grommeted drain holes allow the bag to breathe. The bag is also equipped with large carrying straps and side pockets. **The bag is *not* intended for shipping your mask as air cargo.** The part number for the bag is KMDSI Part #500-901.



Fig. 7.9 To help protect your mask during travel, use the mask carrying bag.

Appendix 1

Torque Specifications for KMB 18A/B & 28

Location Number	KMDSI Part #	Description	Torque:	
			inch pounds	kg cm
8	550-038	Nut, regulator mount	100	112
15	530-095	Band screw	26	30
20	530-317	Nut	45	50
22	530-317	Nut	20	23
25	530-050	Screw	18	20
29	530-052	Screw	15	17
30	530-035	Screw	12	13
38	530-045	Screw	12	13
46	550-055	Packing Nut	40 after seating	
49	530-030	Screw	8	10
61a	550-046	Inlet Nipple 'A'	40	46
61b	550-048	Inlet Nipple 'B'	40	46
61c	550-050	Jam Nut "B"	100	112
64	530-021	Screw	2	3
69	530-035	Screw	14	16
87	550-020	Bonnet	100	112
93	550-024	Stud - side block	50	56
95	550-140	Auxiliary valve body	3 turns by hand, 3 turns by wrench	
99	550-091	Packing nut	45 after seating	
104	555-195	One way Valve	240	270
105	555-117	Inlet adapter to umbilical	180	188
106	505-060	Seat	240	270
112	505-060	Body	240	270
115	550-095	L.P. Plug	50	56
117a	555-152	Regulator hose, side block end	100	112
117a	555-152	Regulator hose, regulator end	50	56
117b	555-154	bent tube assy, side block end	100	112

Table of Equivalents

To convert units appearing in Column 1 (left column) into equivalent values in Column 2 (center column), multiply by factor in Column 3. Example: To convert 7 gallons into cubic inches, multiply 7 x 231 = 1617. To convert units appearing in Column 2 (center) into equivalent values of units in Column 1 (left), divide by factor in Column 3. Example: To convert 25 horsepower into Btu per minute, divide 25 by 0.02356 = 1061

TO CONVERT	INTO	MULTIPLY BY
INTO	TO CONVERT	DIVIDE BY
Atmospheres	Feet of Water	33.9
Atmospheres	Inches of Mercury (Hg)	29.92
Atmospheres	PSI (LBS per Sq. Inch)	14.7
BTU	Foot Pounds	778.3
BTU per hour	Watts	0.2931
BTU per minute	HorsePower	0.02356
Celsius (Centigrade)	Fahrenheit	°C x 1.8 + 32
Centimeters	Inches	0.3937
Cubic Centimeters	Gallons (U.S. Liquid)	0.0002642
Cubic Centimeters	Liters	0.0001
Cubic Feet	Cubic Inches	1728
Cubic Feet	Gallons (U.S. Liquid)	7.48052
Cubic Inches	Cubic Feet	0.0005787
Cubic Inches	Gallons (U.S. Liquid)	0.004329
Days	Seconds	86.400
Degrees (Angle)	Radians	0.01745
Feet	Meters	0.3048
Feet	Miles	0.0001894
Feet of Water	Atmospheres	0.0295
Feet of Water	Inches of Mercury (Hg)	0.8826
Feet of Water	PSI (Lbs per Sq. Inch)	0.4335
Feet per Minute	Miles per Hour	0.01136
Feet per Second	Miles per Hour	0.6818
Foot-Pounds	BTU	0.001286
Foot-Pounds per Minute	Horsepower	0.0000303
Foot-Pounds per Second	Horsepower	0.001818
Gallons (U.S. Liquid)	Cubic Feet	0.1337
Gallons (U.S. Liquid)	Cubic Inches	231
Gallons of Water	Pounds of Water	8.3453
Horsepower	BTU per Minute	42.44
Horsepower	Foot-Pound per Minute	33,000
Horsepower	Foot Pounds per Second	550
Horsepower	Watts	745.7
Hours	Days	0.04167
Hours	Weeks	0.005952
Inches	Centimeters	2.54
Inches of Mercury (Hg)	Atmospheres	0.03342
Inches of Mercury (Hg)	Feet of Water	1.133
Inches of Mercury (Hg)	PSI (Lbs. per Sq. Inch)	0.4912
Inches of Water	PSI (Lbs. per Sq. Inch)	0.03613
Liters	Cubic Centimeters	1000
Liters	Gallons (U.S. Liquid)	0.2642
Micron	Inches	0.00004
Miles (Statute)	Feet	5280
Miles per hour (MPH)	Feet per Minute	88
Miles per hour	Feet per Second	1.467
Ounces (Weight)	Pounds	0.0625
Ounces (Liquid)	Cubic Inches	1.805
Pints (Liquid)	Quarts (Liquid)	0.5
Pounds	Grains	7000
Pounds	Grams	453.59
Pounds	Ounces	16
PSI (Pounds per Sq. Inch)	Atmospheres	0.06804
PSI (Pounds per Sq. Inch)	Feet of Water	2.307
PSI (Pounds per Sq. Inch)	Inches of Mercury (Hg)	2.036
Quarts	Gallons	0.25
Square Feet	Square Inches	144
Temperature (°F - 32)	Temperature (°C)	0.5555
Tons (U.S.)	Pounds	2000
Watts	Horsepower	0.001341